

(), , . The low V_{th} series is specially designed to use in synchronous rectification power systems with low driving voltage.

• () &



Switched mode power supply

Parameter	Value	Unit
$V_{DS, min} @ T_{j(max)}$	100	V
$I_{D, pulse}$	90	A
$R_{DS(ON), max} @ V_{GS}=10V$	20	
Q_g	16.2	nC

Product Name	Package	Marking
SFG10S20DF	TO252	SFG10S20D

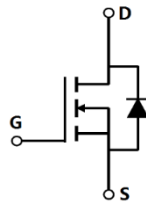

Dynamic Characteristics

Parameter	Symbol	Min.	Typ.	Max.	Unit	Test condition
Input capacitance	C_{iss}		1004		pF	$V_{GS}=0\text{ V}$, $V_{DS}=50\text{ V}$, 100 kHz
Output capacitance	C_{oss}		185		pF	
Reverse transfer capacitance	C_{rss}		9.8		pF	
Turn-on delay time	$t_{d(on)}$		16.6		ns	$V_{GS}=10\text{ V}$, $V_{DS}=50\text{ V}$, $R_G=10\ \Omega$, $I_D=5\text{ A}$
Rise time	t_r		3.8		ns	
Turn-off delay time	$t_{d(off)}$		75.5		ns	
Fall time	t_f		46		ns	

Gate Charge Characteristics

Parameter	Symbol	Min.	Typ.	Max.	Unit	Test condition
Total gate charge	Q_g		16.2		nC	$V_{GS}=10\text{ V}$, $V_{DS}=50\text{ V}$, $I_D=$

Electrical Characteristics Diagrams

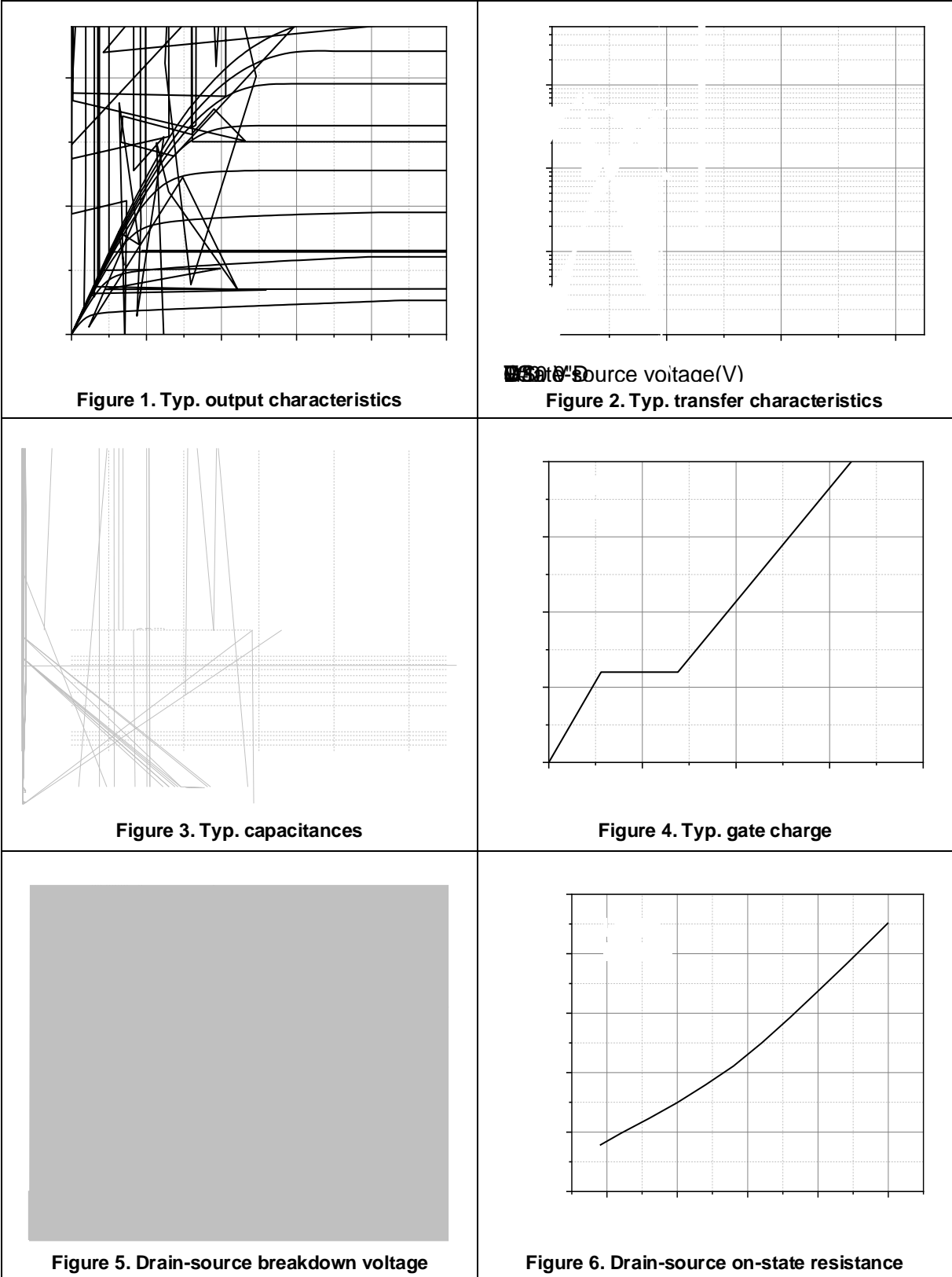

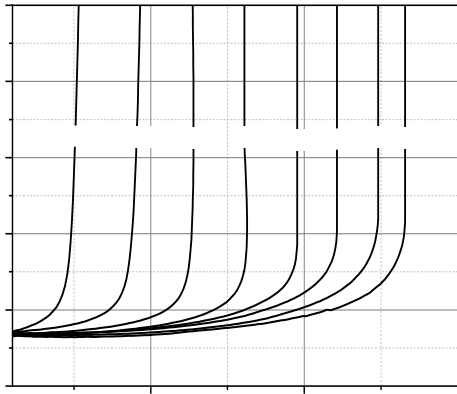

Figure 7. Drain-source on-state resistance

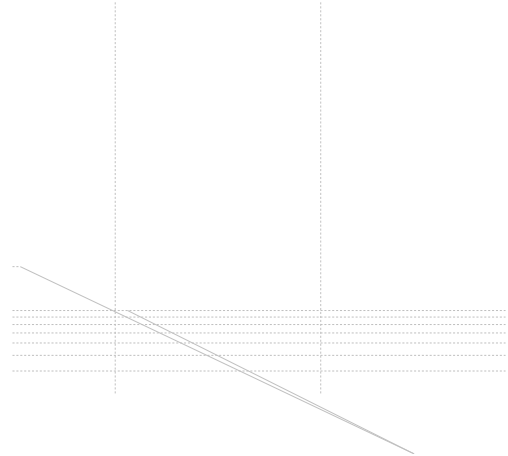

Figure 8. Forward characteristic of body diode

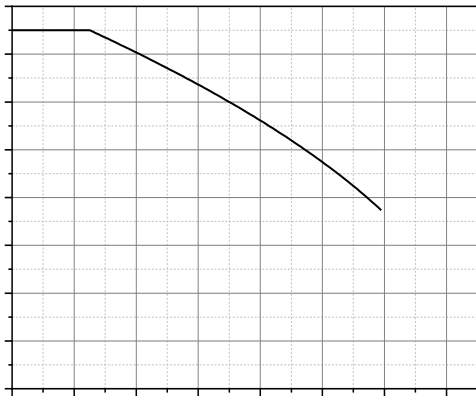

Figure 9. Drain current

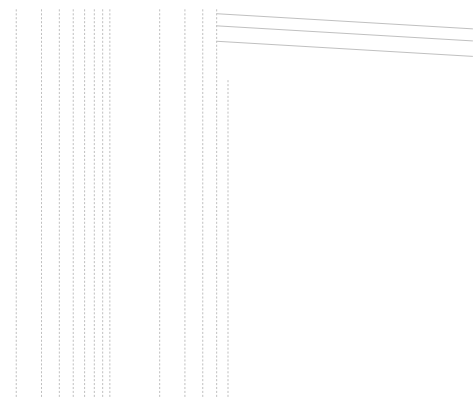

Figure 10. Safe operation area $T_c = 25\text{ }^\circ\text{C}$

Test circuits and waveforms

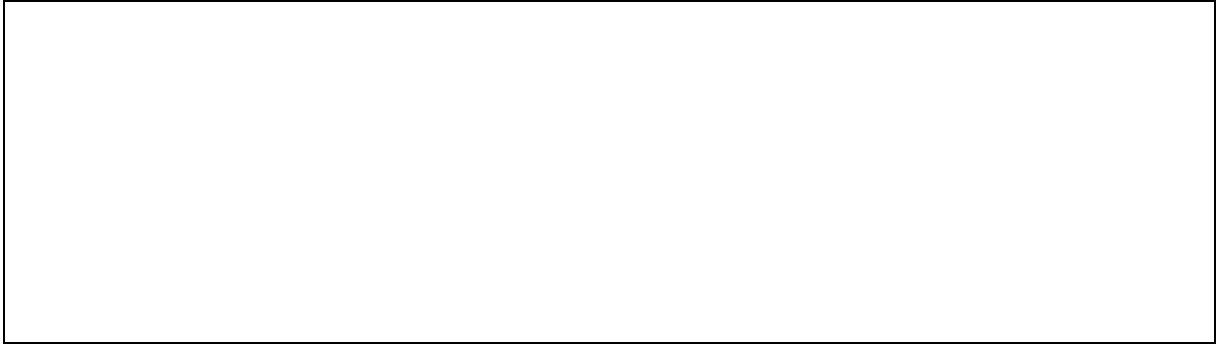

Figure 1. Gate charge test circuit & waveform

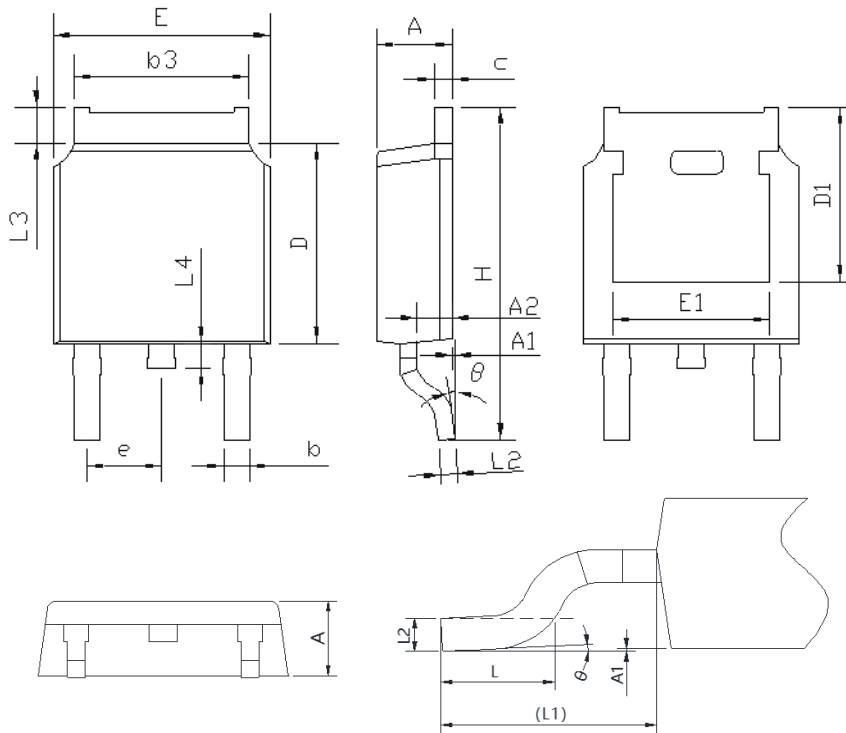

Figure 2. Switching time test circuit & waveforms

Package Information

Symbol	mm		
	Min	Nom	Max
A	2.20	2.30	2.38
A1	0.00	-	0.10
A2	0.90	1.01	1.10
b	0.72	-	0.85
b1	0.71	0.76	0.81

Package Information



Symbol	mm		
	Min	Nom	Max
A	2.20	2.30	2.38
A1	0.00	-	0.20
A2	0.97	1.07	1.17
b	0.68	0.78	0.90
b3	5.20	5.33	5.46
c	0.43	0.53	0.61
D	5.98	6.10	6.22
D1	5.30 REF		
E	6.40	6.60	6.73
E1	4.63	-	-
e	2.286 BSC		
H	9.40	10.10	10.50
L	1.38	1.50	1.75
L1	2.90 REF		
L2	0.51 BSC		
L3	0.88	-	1.28
L4	0.50	-	1.00
θ	0	-	

Version 2: TO252-P package outline dimension

Ordering Information

Package Type	Units/ Reel	Reels / Inner Box	Units/ Inner Box	Inner Boxes/ Carton Box	Units/ Carton Box
TO252-J	2500	2	5000	5	25000
TO252-P	2500	2	5000	5	25000

Product Information

Product	Package	Pb Free	RoHS	Halogen Free
SFG10S20DF	TO252	yes	yes	yes