

Features

- Low gate charge
- 100% avalanche tested
- Improved dv/dt capability
- RoHS compliant
- Halogen free package
- JEDEC Qualification

Absolute Maximum Ratings

Parameter	Symbol	TMP16N60A(G)	TMPF16N60A(G)	Unit	
Drain-Source Voltage	V_{DSS}	600		V	
Gate-Source Voltage	V_{GS}	30		V	
Continuous Drain Current	I_D	$T_C = 25$	16	16 *	A
		$T_C = 100$	9.97	9.97 *	A
Pulsed Drain Current ^(Note 1)	I_{DM}	64	64 *	A	
Single Pulse Avalanche Energy ^(Note 2)	E_{AS}	194		mJ	
Repetitive Avalanche Current ^(Note 1)	I_{AR}	16		A	
Repetitive Avalanche Energy ^(Note 1)	E_{AR}	29		mJ	
Power Dissipation	P_D	$T_C = 25$	290	48	W
		Derate above 25	2.32	0.38	W/
Peak Diode Recovery dv/dt ^(Note 3)	dv/dt	4.5		V/ns	
Operating Junction and Storage Temperature Range	T_J, T_{STG}	-55~150			
Maximum lead temperature for soldering purposes,	T_L	300			

Thermal Characteristics

Parameter	Symbol	TMP16N60A(G)	TMPF16N60A(G)	Unit
Maximum Thermal resistance, Junction-to-Case	$R_{\theta JC}$	0.43	2.6	



Electrical Characteristics : $T_C=25$, unless otherwise noted

Note :



TMP16N60A(G)/TMPF16N60A(G)

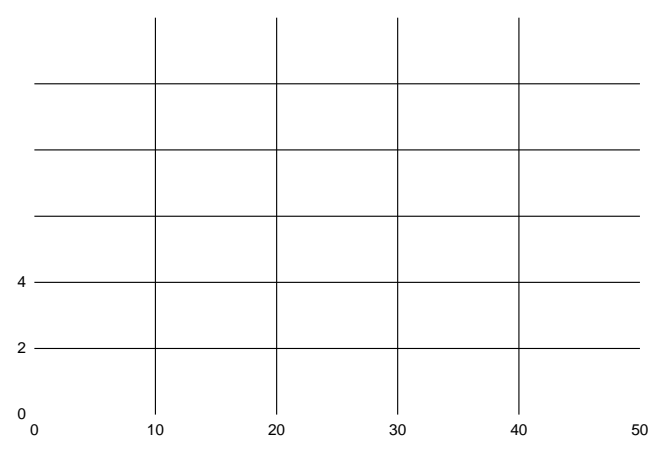
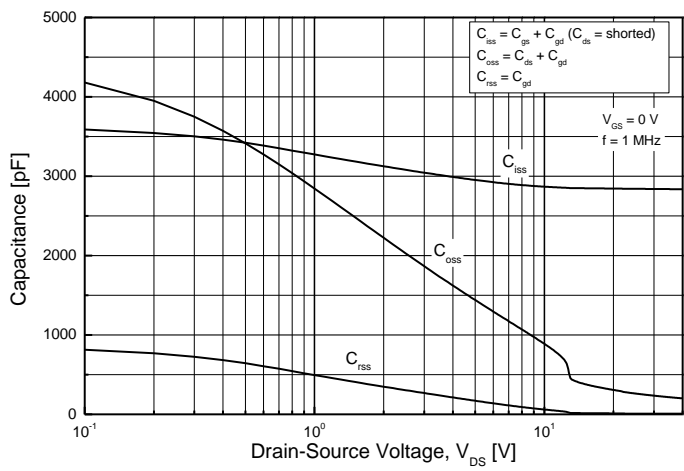
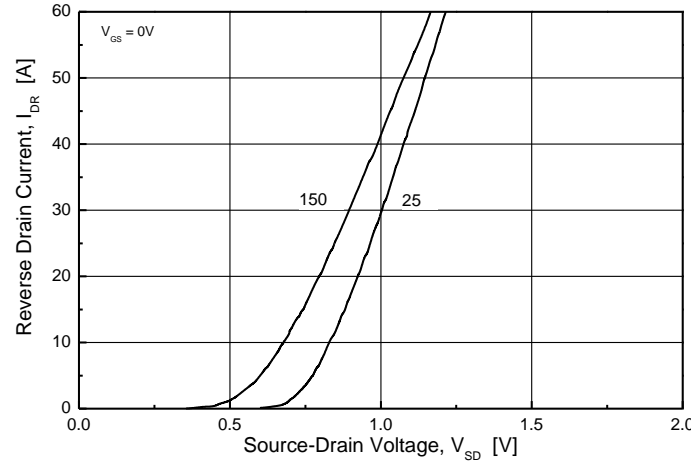
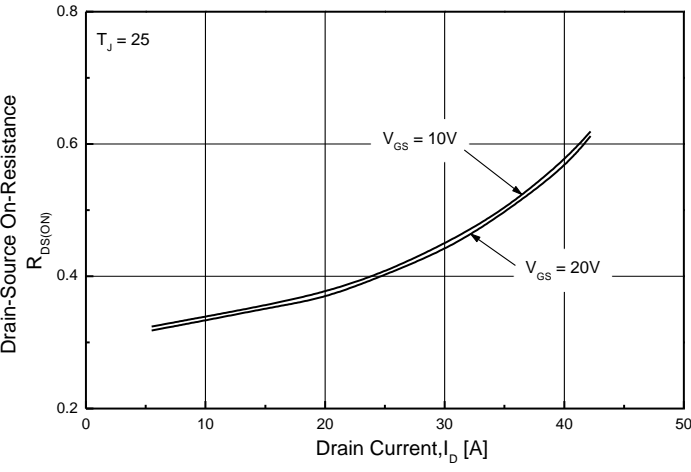
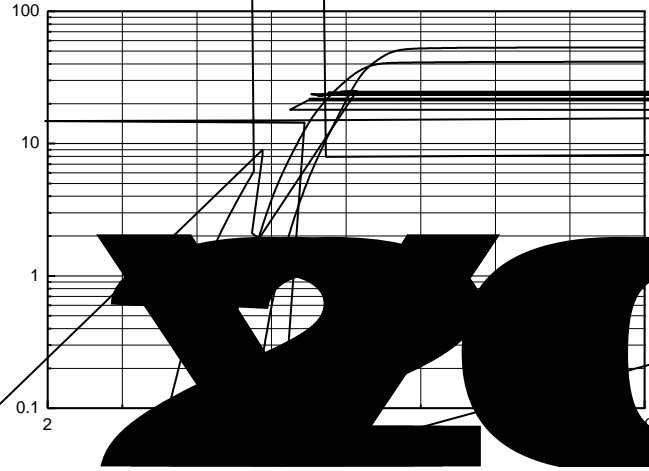
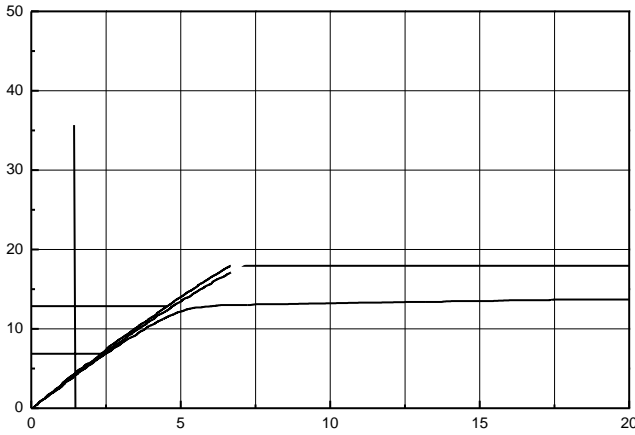



TMP16N60A(G)/TMPF16N60A(G)

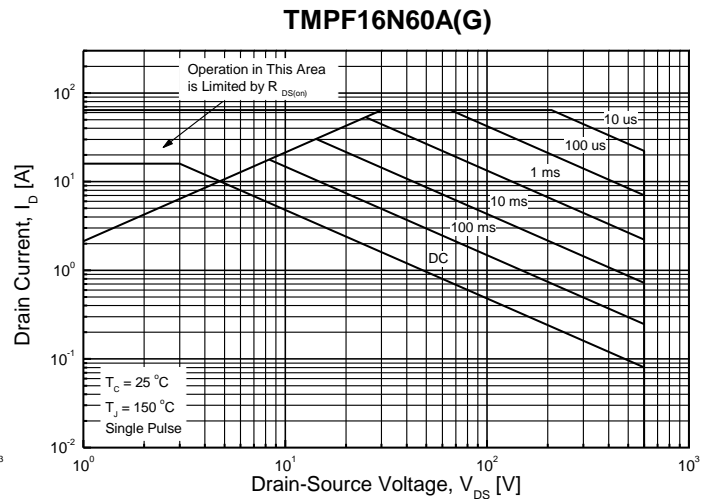
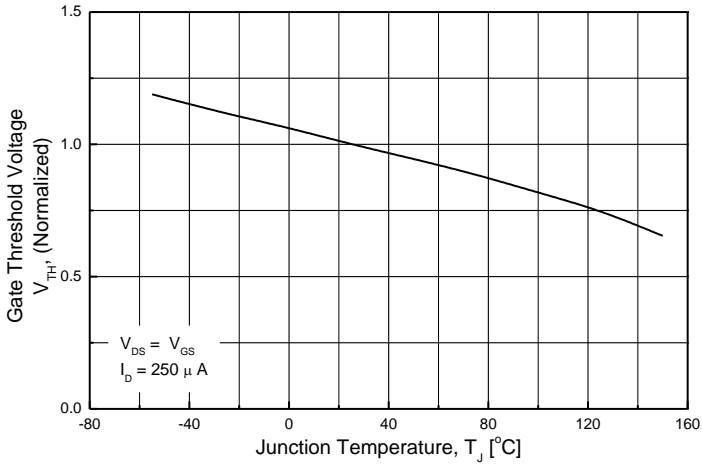
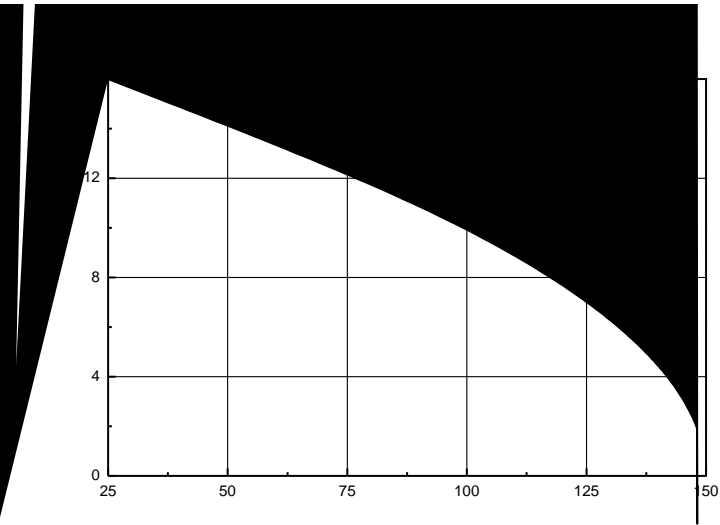
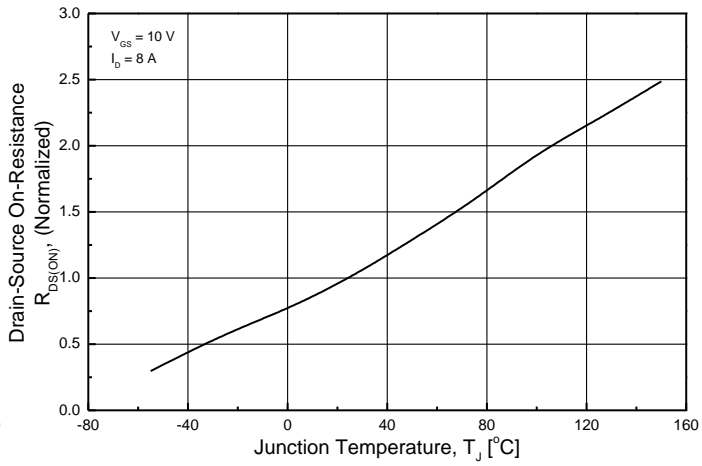
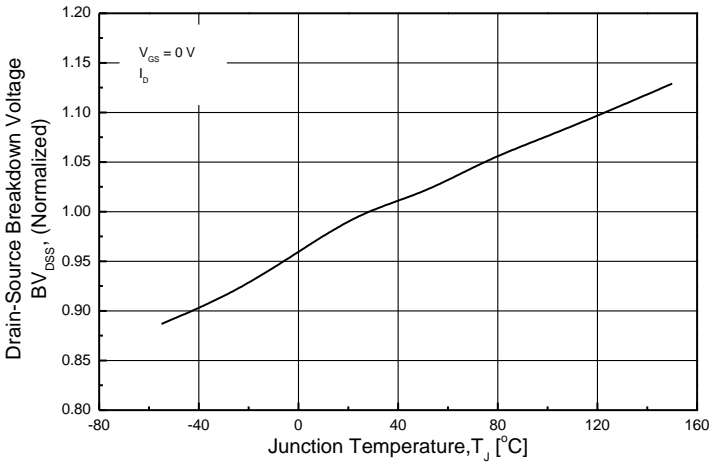

TMP16N60A(G)



TMPF16N60A(G)

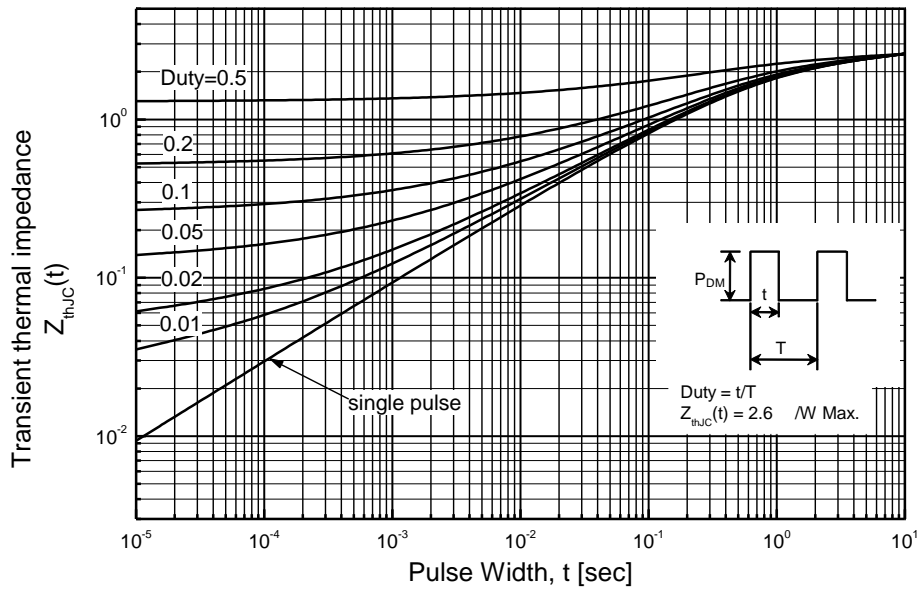

TO-220AB-3L MECHANICAL DATA

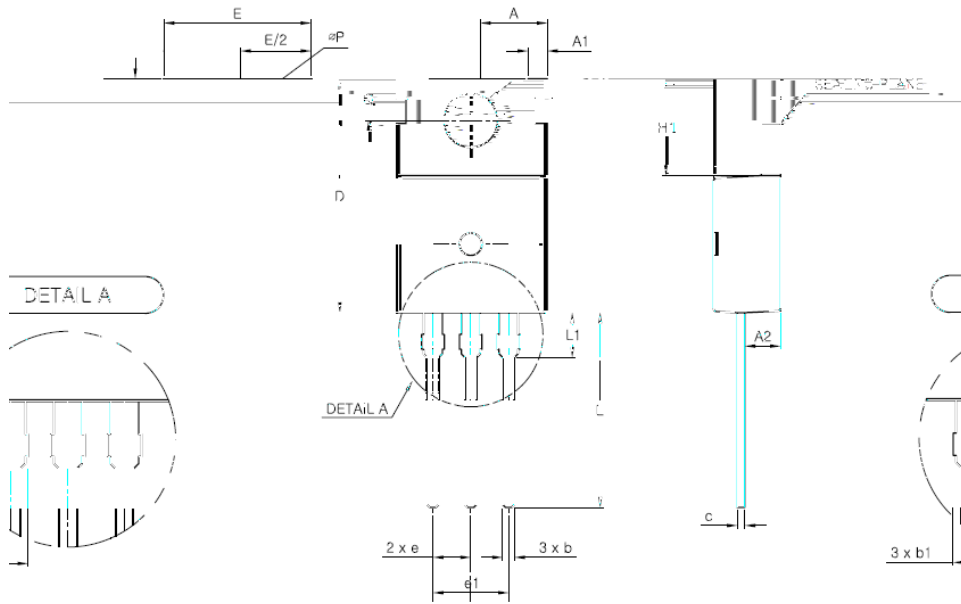

SYMBOL	MIN	MAX
A	4.30	4.70
A1	1.22	1.40
A2	2.20	2.79
b	0.70	0.91
b1	1.15	1.62
c	0.36	0.60
D	14.99	15.90
E	9.70	10.41
e	2.54 TYP	
e1	5.08 BSC	
H1	5.97	6.70
L	12.88	13.97
L1	3.31	3.81
ØP	3.40	3.88
Q	2.60	2.90

TO-220F-3L MECHANICAL DATA

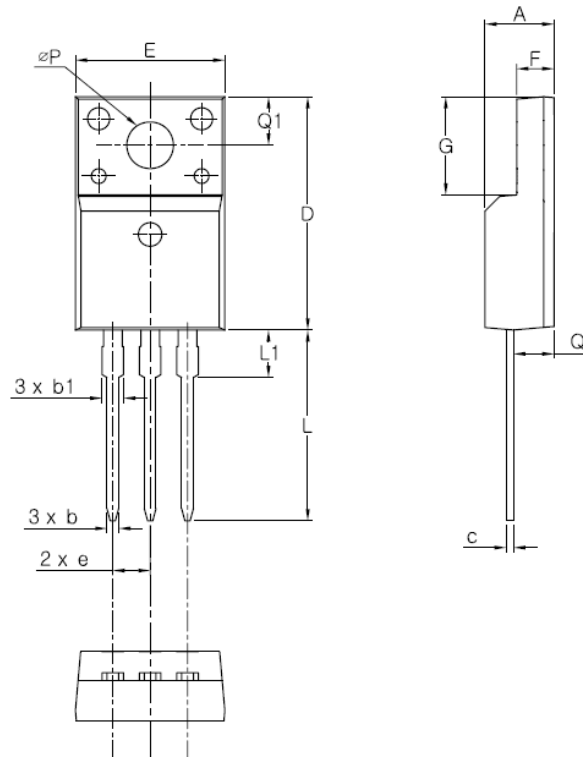

Disclaimer :

TRinno technology reserves the right to make changes without notice to products herein to improve reliability, performance, or design. The information given in this document is believed to be accurate and reliable. However, it shall in no event be regarded as a guarantee of conditions and characteristics. With respect to any information regarding the