

Features

- Low gate charge
- 100% avalanche tested
- Improved dv/dt capability
- RoHS compliant
- Halogen free package
- JEDEC Qualification
- Improved ESD performance

$$V_{DSS} = 440 \text{ V @ } T_{jmax}$$

$$I_D = 2 \text{ A}$$

$$R_{DS(on)} = 3.4 \text{ (max) @ } V_{GS} = 10 \text{ V}$$

Absolute Maximum Ratings

Parameter	Symbol	TMD3N40ZG/TMU3N40ZG	Unit
Drain-Source Voltage	V_{DS}	400	V
Gate-Source Voltage	V_{GS}	±30	V
Continuous Drain Current	I_D	$T_C = 25 \text{ }^\circ\text{C}$	2.0*
		$T_C = 100 \text{ }^\circ\text{C}$	1.2*
Pulsed Drain Current ^(Note 1)	I_{DM}	8*	A
Single Pulse Avalanche Energy ^(Note 2)	E_{AS}	46	mJ
Repetitive Avalanche Current ^(Note 1)	I_{AR}	2	A
Repetitive Avalanche Energy ^(Note 1)	E_{AR}	3	mJ
Power Dissipation	P_D	$T_C = 25 \text{ }^\circ\text{C}$	30
		Derate above 25 $^\circ\text{C}$	0.24
Peak Diode Recovery dv/dt ^(Note 3)	dv/dt	4.5	V/ns
Operating Junction and Storage Temperature Range	T_J, T_{STG}	-55~150	$^\circ\text{C}$
Maximum lead temperature for soldering purposes,	T_L	300	$^\circ\text{C}$

Thermal Characteristics

Parameter	Symbol	TMD3N40ZG/TMU3N40ZG	Unit
Maximum Thermal resistance, Junction-to-Case	R_{JC}	4.2	$^\circ\text{C/W}$
Maximum Thermal resistance, Junction-to-Ambient	R_{JA}		



Electrical Characteristics : $T_C=25^\circ\text{C}$, unless otherwise noted

Note :

1. Repeated rating : Pulse width limited by safe operating area
2. $L=10\text{mH}$, $I_{AS}=2\text{A}$, $V_{DD}=50\text{V}$, $R_G=25\ \mu\text{s}$, Starting $T_J=25^\circ\text{C}$
3. I_{SD} μs , V_{DD} DS , Starting $T_J=25^\circ\text{C}$
5. Essentially Independent of Operating Temperature Typical Characteristics



TMD3N40ZG/TMU3N40ZG

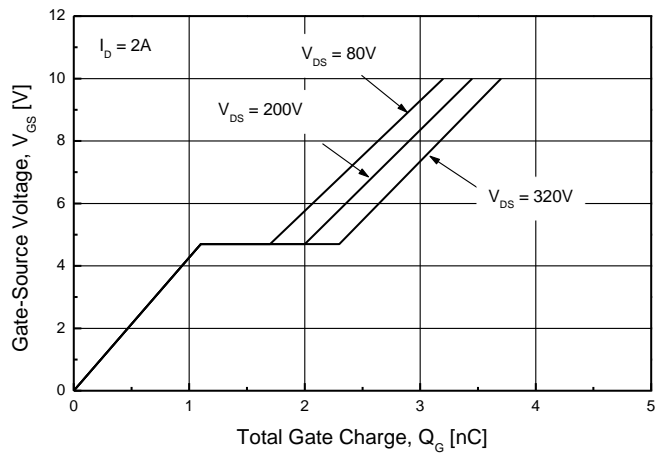
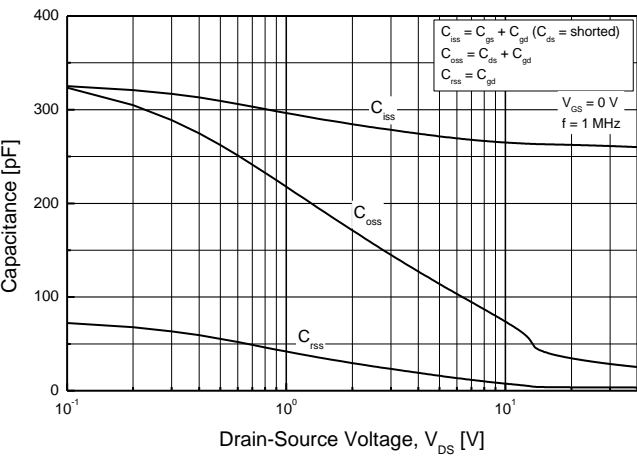
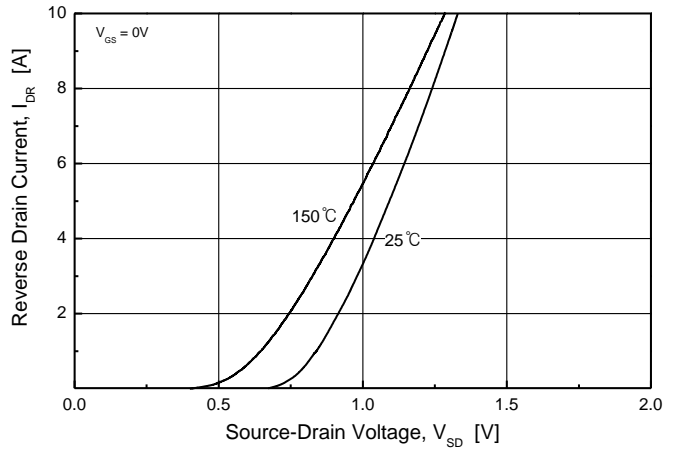
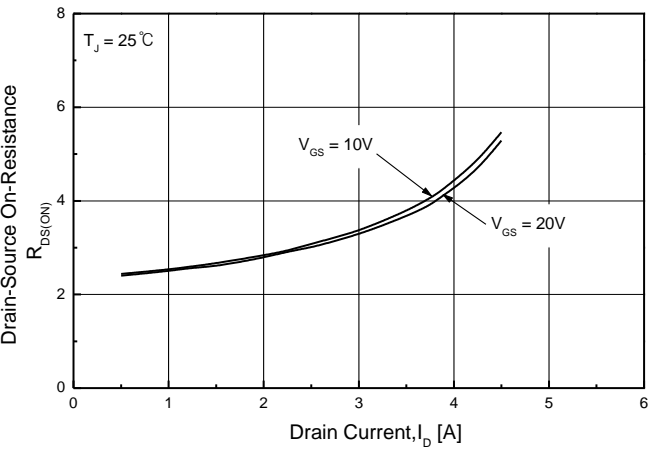
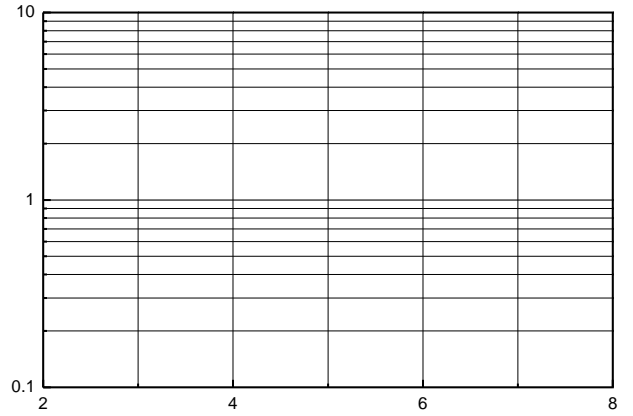
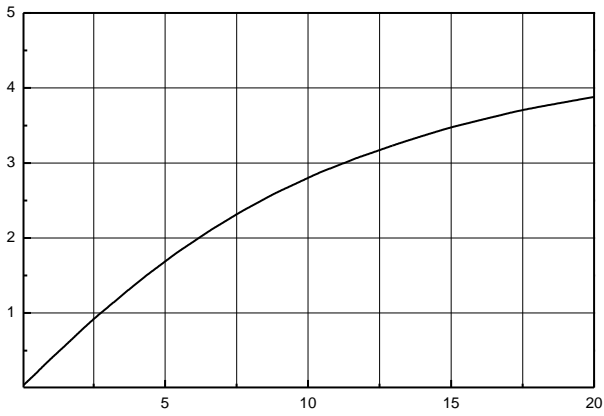



TMD3N40ZG/TMU3N40ZG

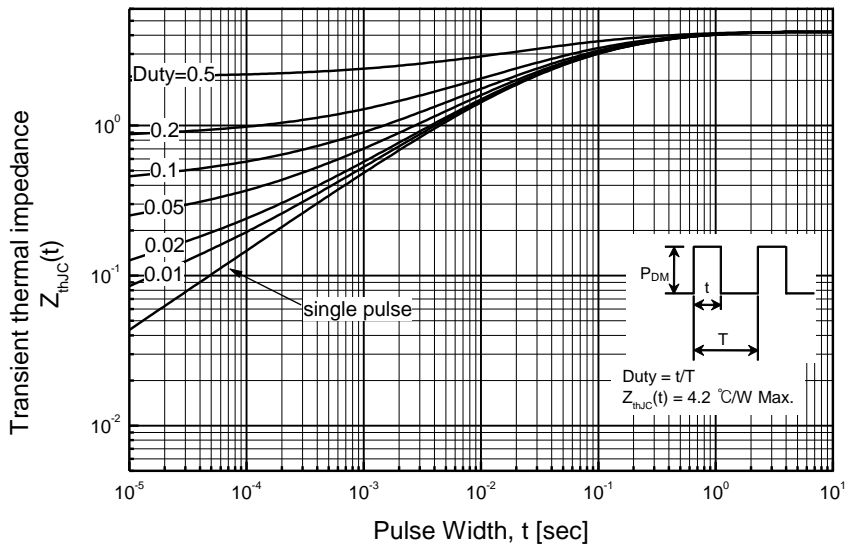
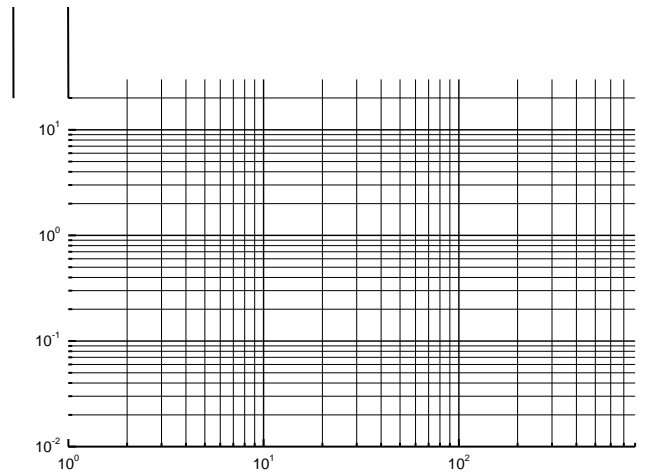
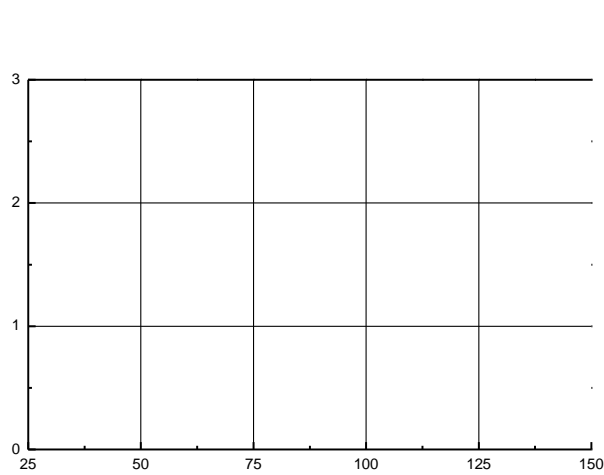
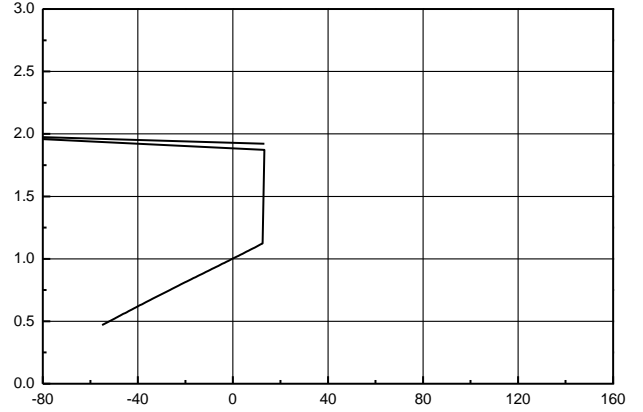
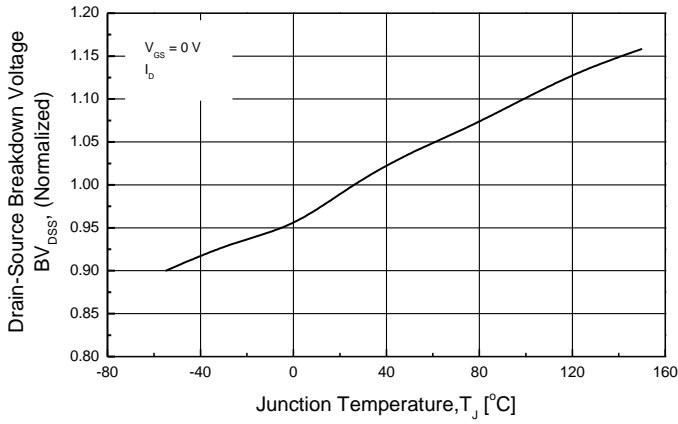



TO-252 (D-PAK) MECHANICAL DATA

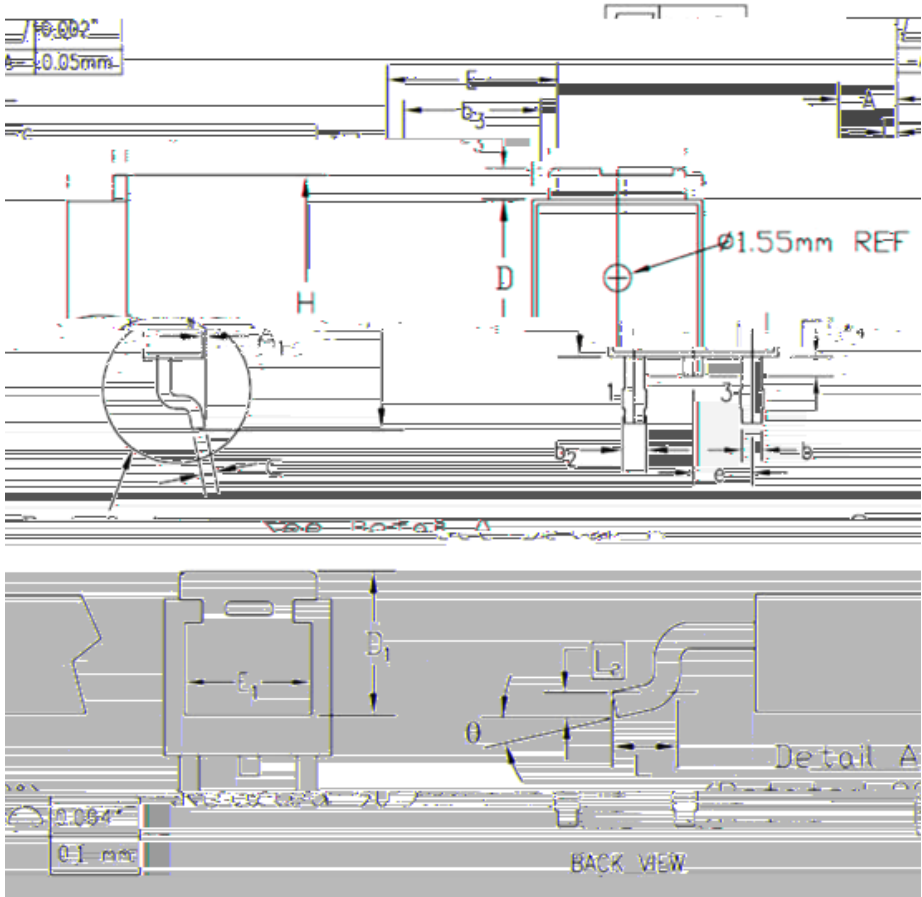

SYMBOL	INCHES		MILLIMETERS		NOTES
	MIN	MAX	MIN	MAX	
A	0.285	0.285	0.004	0.004	1, 3
A ₁			0.005		0.13
b	0.625	0.625	0.035	0.64	0.89
b ₂	0.633	0.645	0.84	1.34	
D	0.255	0.255	0.05	0.05	1
D ₁	0.235	0.245	0.57	0.22	1
D ₂	0.205		0.21		2
E	0.250	0.265	0.35	0.23	
E ₁	0.190		0.83		2
e	0.090	BSC	2.29	BSC	
E ₂	0.386	0.410	0.65	0.43	
L	0.055	0.070	0.40	0.78	4
L ₂	0.020	BSC	0.51	BSC	
L ₃	0.035	0.050	0.89	1.27	
L ₄	0.025	0.040	0.64	1.01	3
L ₅	0.0	0.08		0.25	



TO-251 (I-PAK) MECHANICAL DATA

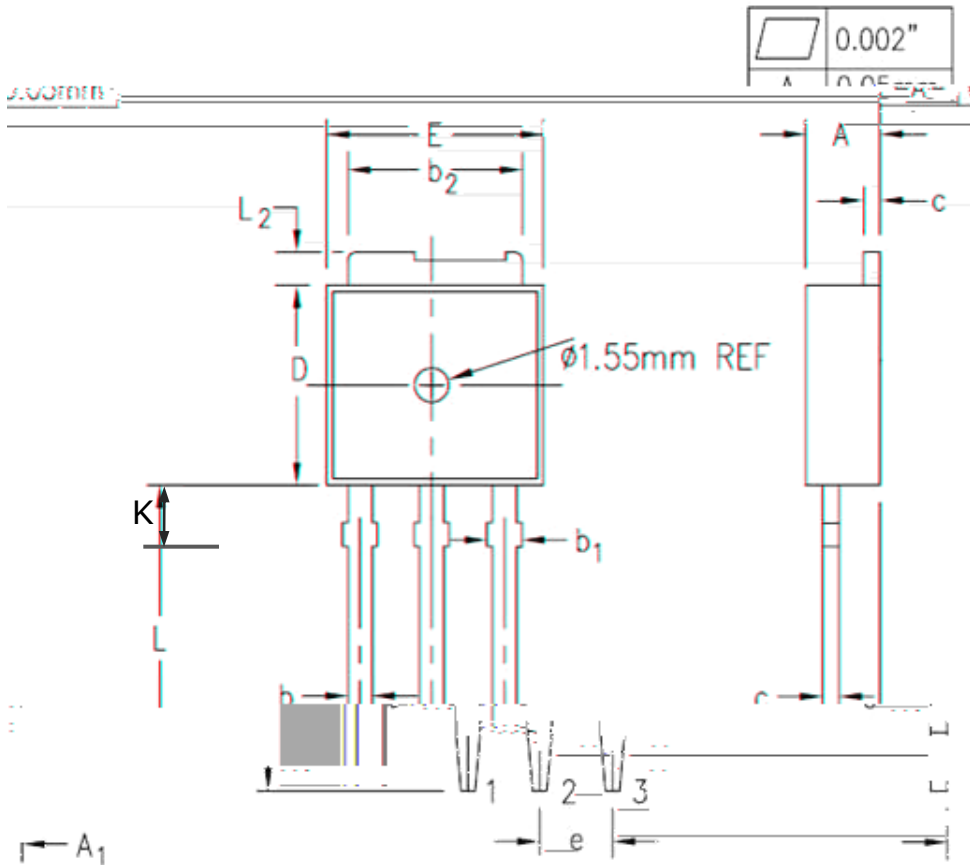

SYMBOL	INCHES		MILIMETERS		NOTES
	MIN.	MAX.	MIN.	MAX.	
A	0.086	0.094	2.19	2.39	
A1	0.040	0.045	1.02	1.14	
b	0.025	0.035	0.64	0.89	
b1	0.037	0.045	0.95	1.14	
b2	0.205	0.215	5.21	5.46	
c	0.018	0.023	0.46	0.58	
D	0.235	0.245	5.97	6.22	
E	0.250	0.265	6.35	6.73	
e	0.090 TYP.		2.28 TYP.		
L	0.350	0.380	8.89	9.65	
L2	0.035	0.050	0.89	1.27	
K	0.079	0.096	2.00	2.44	