

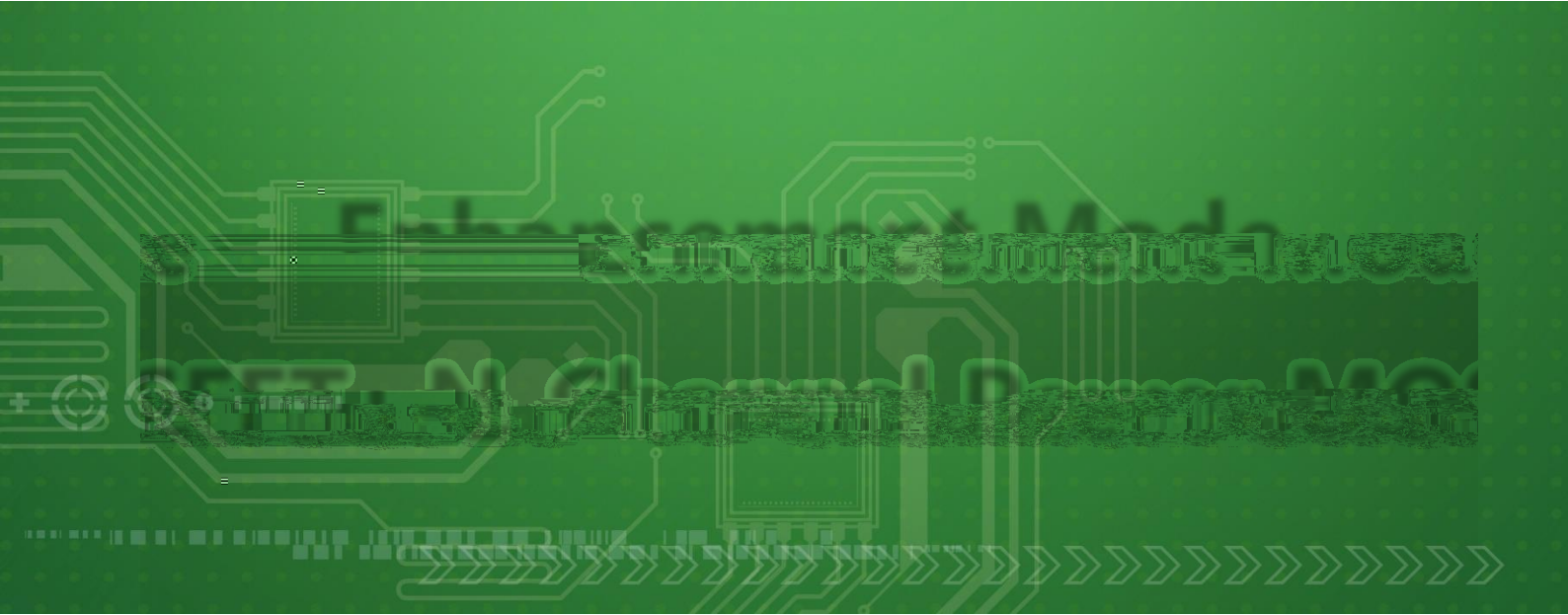

ORIENTAL  
SEMICONDUCTOR

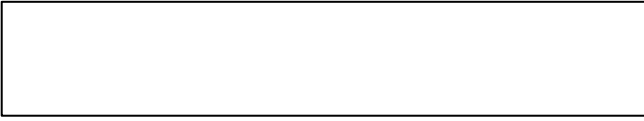



---



---



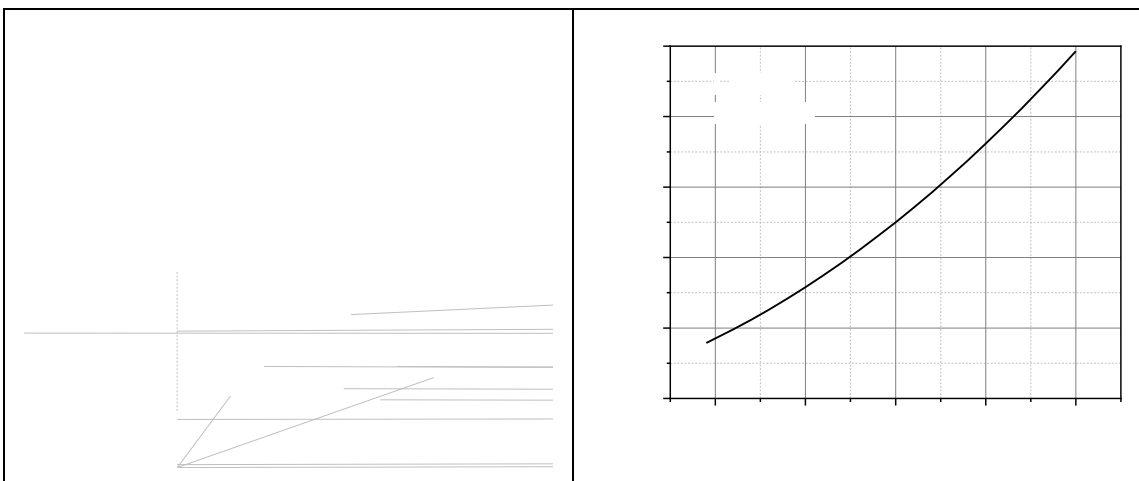
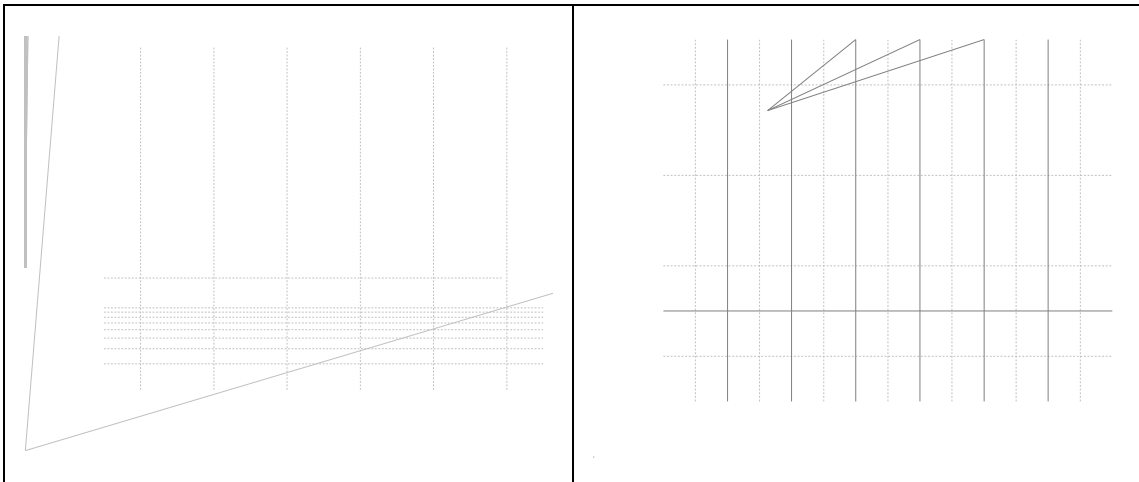
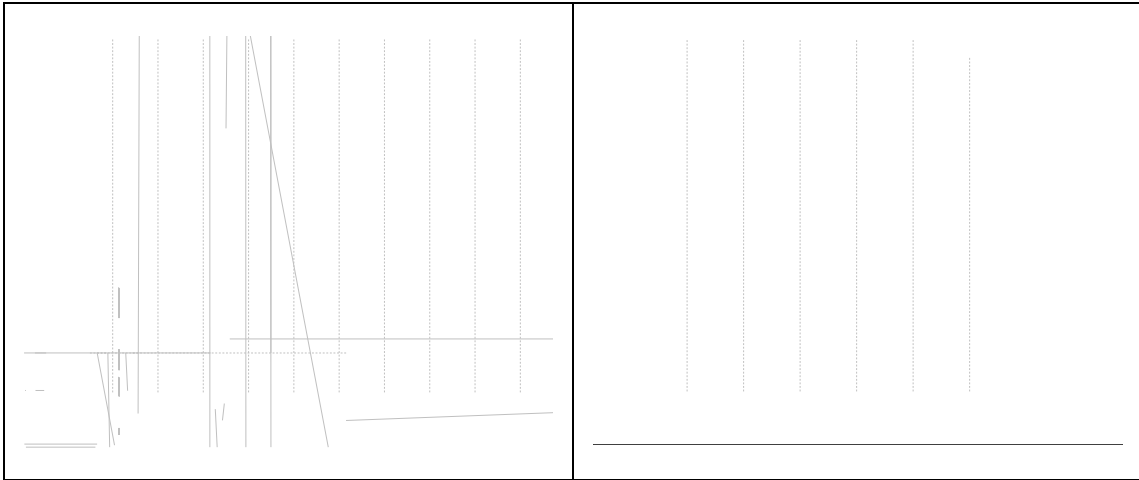

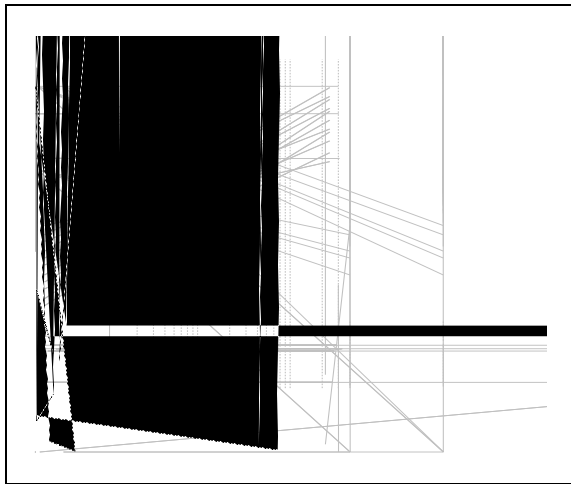
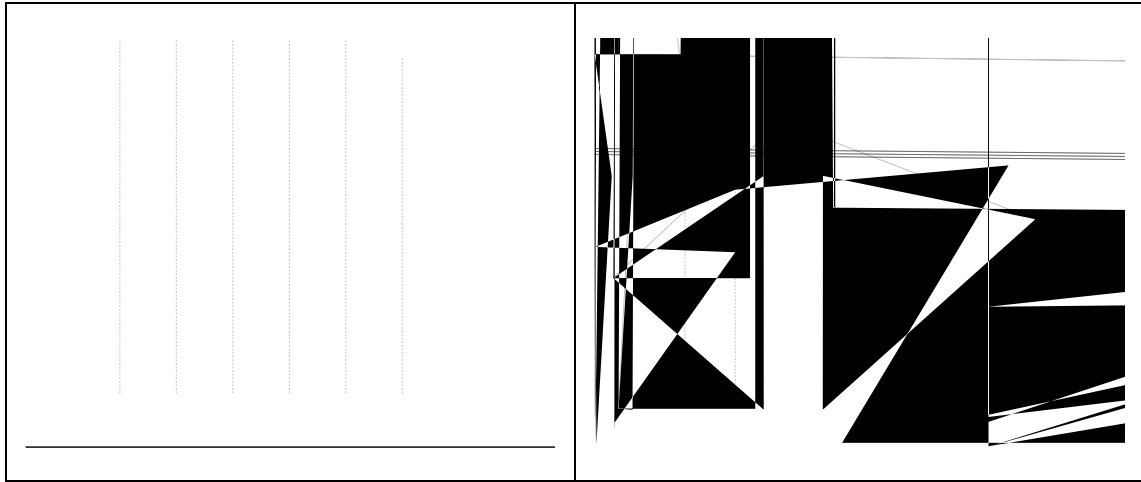

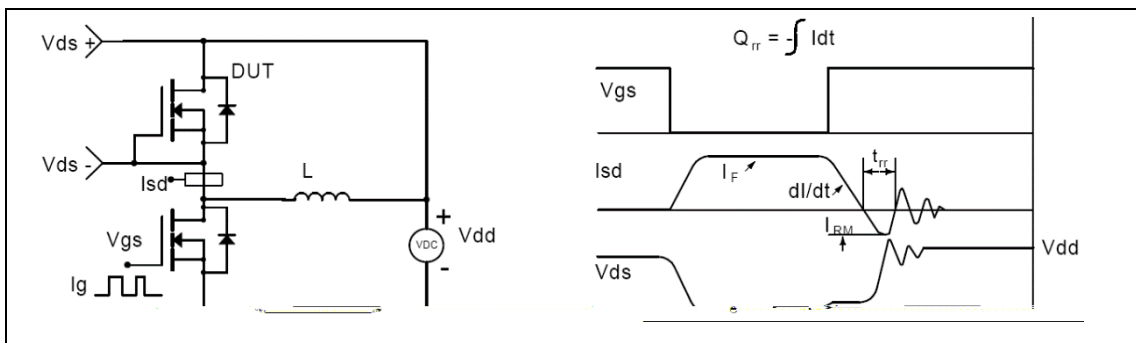
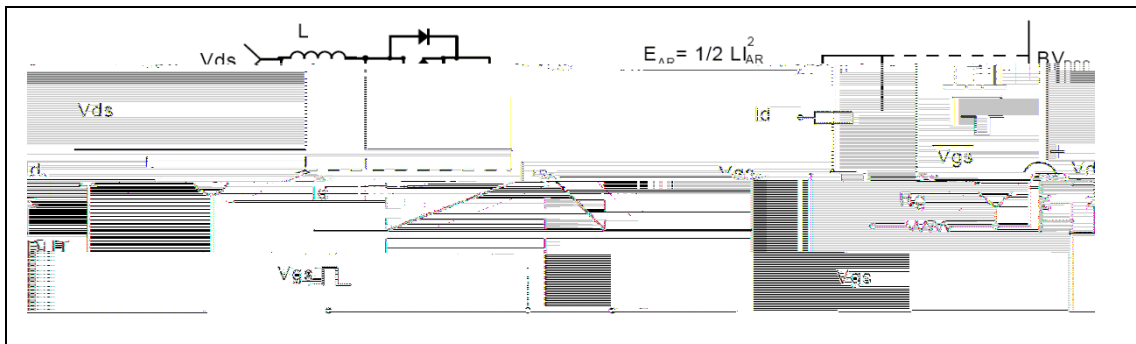
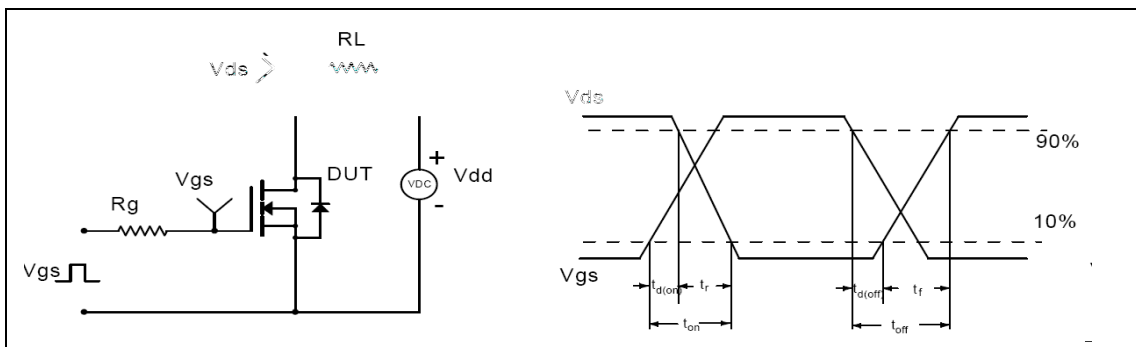
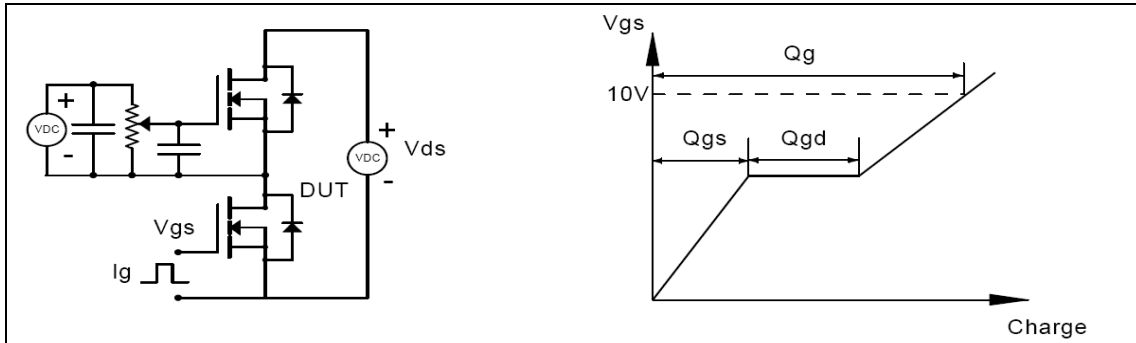



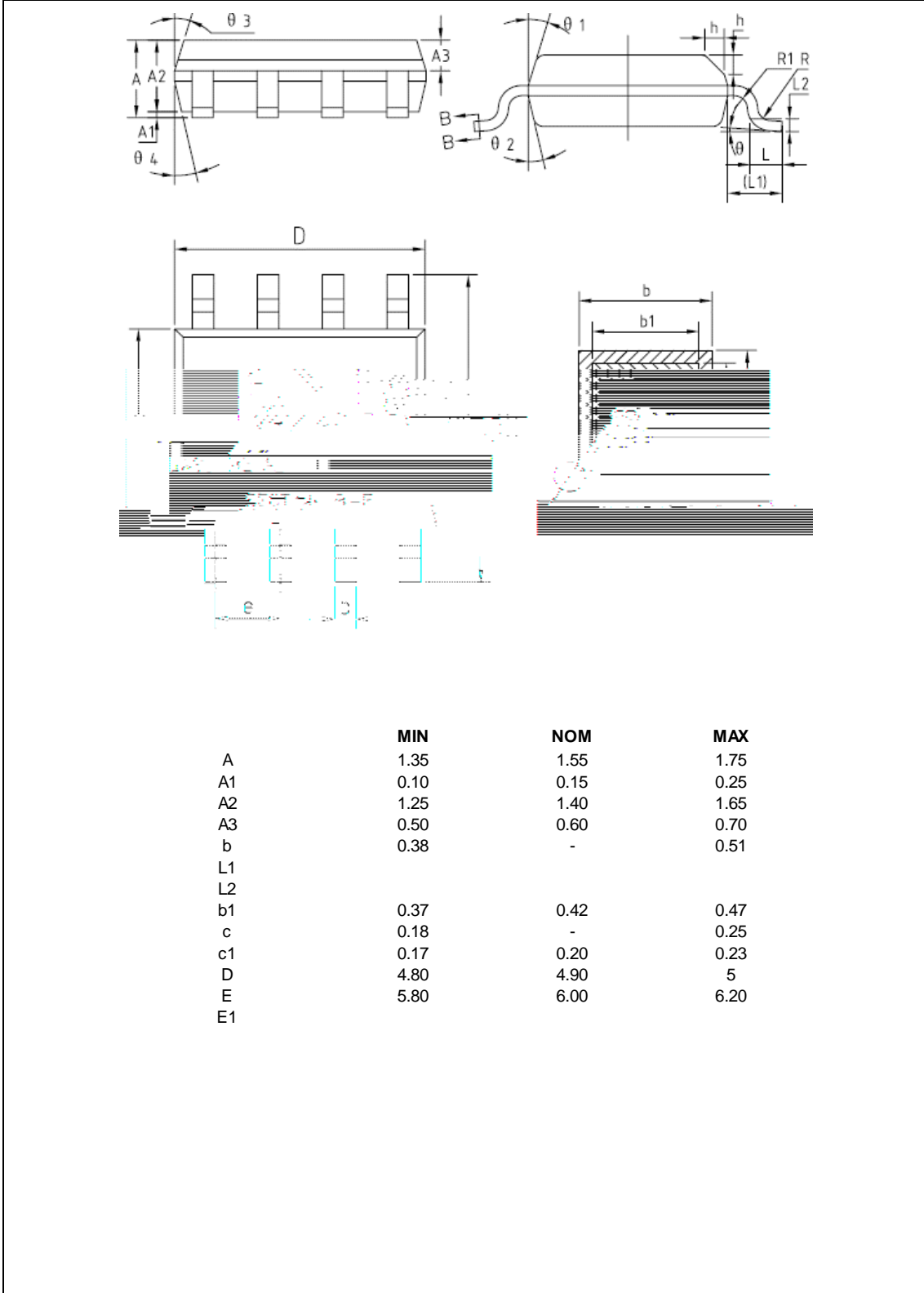

---

---

---

---