

- High breakdown voltage to 1200V for improved reliability
- Trench-Stop Technology offering :
 - Very tight parameter distribution
 - High ruggedness, temperature stable behavior
 - Short circuit withstand time – 10μs
 - Low $V_{CE(SAT)}$
 - Easy parallel switching capability due to positive temperature coefficient in $V_{CE(SAT)}$
- Enhanced avalanche capability

- Uninterruptible Power Supplies
- Welding
- PFC applications

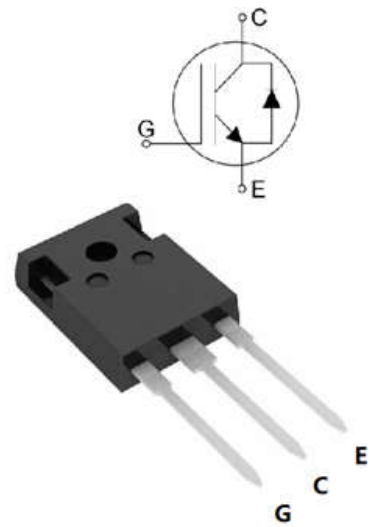

Product	Package	Packaging
YGW40N120F1C	TO247	Tube

Parameter	Symbol	Value	Unit
Collector-Emitter Breakdown Voltage	V_{CE}	1200	V
DC collector current, limited by T_{jmax} $T_C = 25^\circ C$ $T_C = 100^\circ C$	I_C	80 40	A
Diode Forward current, limited by T_{jmax} $T_C = 25^\circ C$ $T_C = 100^\circ C$	I_F	80 40	A
Continuous Gate-emitter voltage	V_{GE}	± 20	V
Transient Gate-emitter voltage	V_{GE}	± 30	V
Turn off safe operating area $V_{CE} = 1200V$, $T_j = 150^\circ C$	-	120	A
Pulsed collector current, $V_{GE} = 15V$, t_p limited by T_{jmax}	I_{CM}	120	A
Short Circuit Withstand Time, $V_{GE} = 15V$, $V_{CE} = 600V$	T_{sc}	10	μs
Power dissipation , $T_j = 25^\circ C$	P_{tot}	250	W
Operating junction temperature	T_j	-40...+150	$^\circ C$
Storage temperature	T_s	-55...+150	$^\circ C$
Soldering temperature, wave soldering 1.6mm (0.063in.) from case for 10s	-	260	$^\circ C$

Parameter	Symbol	Max. Value	Unit
IGBT thermal resistance, junction - case	$R(j-c)$	0.5	K/W
Diode thermal resistance, junction - case	$R(j-c)$	1	K/W
Thermal resistance, junction - ambient	$R(j-a)$	40	K/W

(T_j= 25°C unless otherwise specified) :

Parameter	Symbol	Conditions	Min	Typ	Max	Unit
Collector-Emitter breakdown voltage	BV _{CES}	V _{GE} =0V, I _C =250μA	1200	-	-	V
Gate threshold voltage	V _{GE(th)}	V _{GE} =V _{CE} , I _C =250μA	5.2	6.0	6.8	V
Collector-Emitter Saturation voltage	V _{CE(sat)}	V _{GE} =15V, I _C =40A T _j = 25°C T _j = 150°C	- -	2.0 2.5	2.5 -	V
Zero gate voltage collector current	I _{CES}	V _{CE} = 1200V, V _{GE} = 0V T _j = 25°C T _j = 150°C	- -	- -	100 1000	μA
Gate-emitter leakage current	I _{GES}	V _{CE} = 0V, V _{GE} = ±20V	-	-	100	nA
Transconductance	g _{fs}	V _{CE} =20V, I _C =20A	-	20	-	S

Parameter	Symbol	Conditions	Min	Typ	Max	Unit
-----------	--------	------------	-----	-----	-----	------

Inpu

npu

npu

Parameter	Symbol	Conditions	Min	Typ	Max	Unit
Turn-on delay time	$t_{d(on)}$	$V_{CC} = 600V, I_C = 40A,$ $V_{GE} = 0/15V,$ $R_g = 12\Omega$	-	45	-	ns
Rise time	t_r		-	25	-	ns
Turn-on energy	E_{on}		-	4.05	-	mJ
Turn-off delay time	$t_{d(off)}$		-	200	-	ns
Fall time	t_f		-	75	-	ns
Turn-off energy	E_{off}		-	1.35	-	mJ

($T_j = 25^\circ C$ unless otherwise specified)

Parameter	Symbol	Conditions	Min	Typ
-----------	--------	------------	-----	-----

Fig. 1 FBSOA characteristics

Fig. 2 Load Current vs. Frequency

Fig. 3 Output characteristics

Fig. 4 Saturation voltage characteristics

Fig. 9 Gate charge characteristics

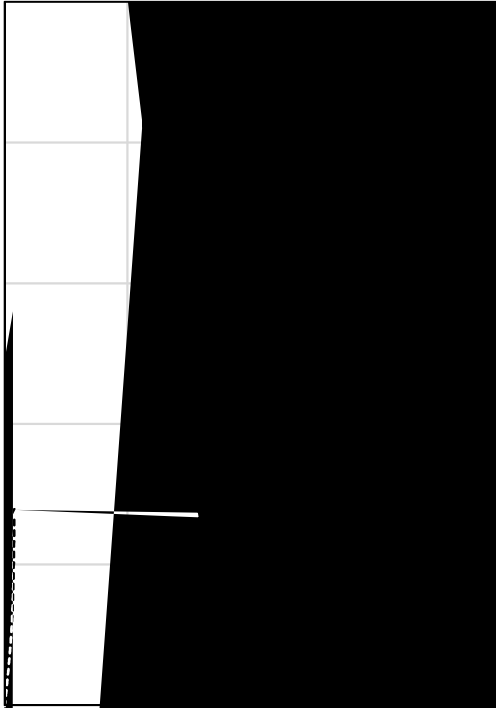
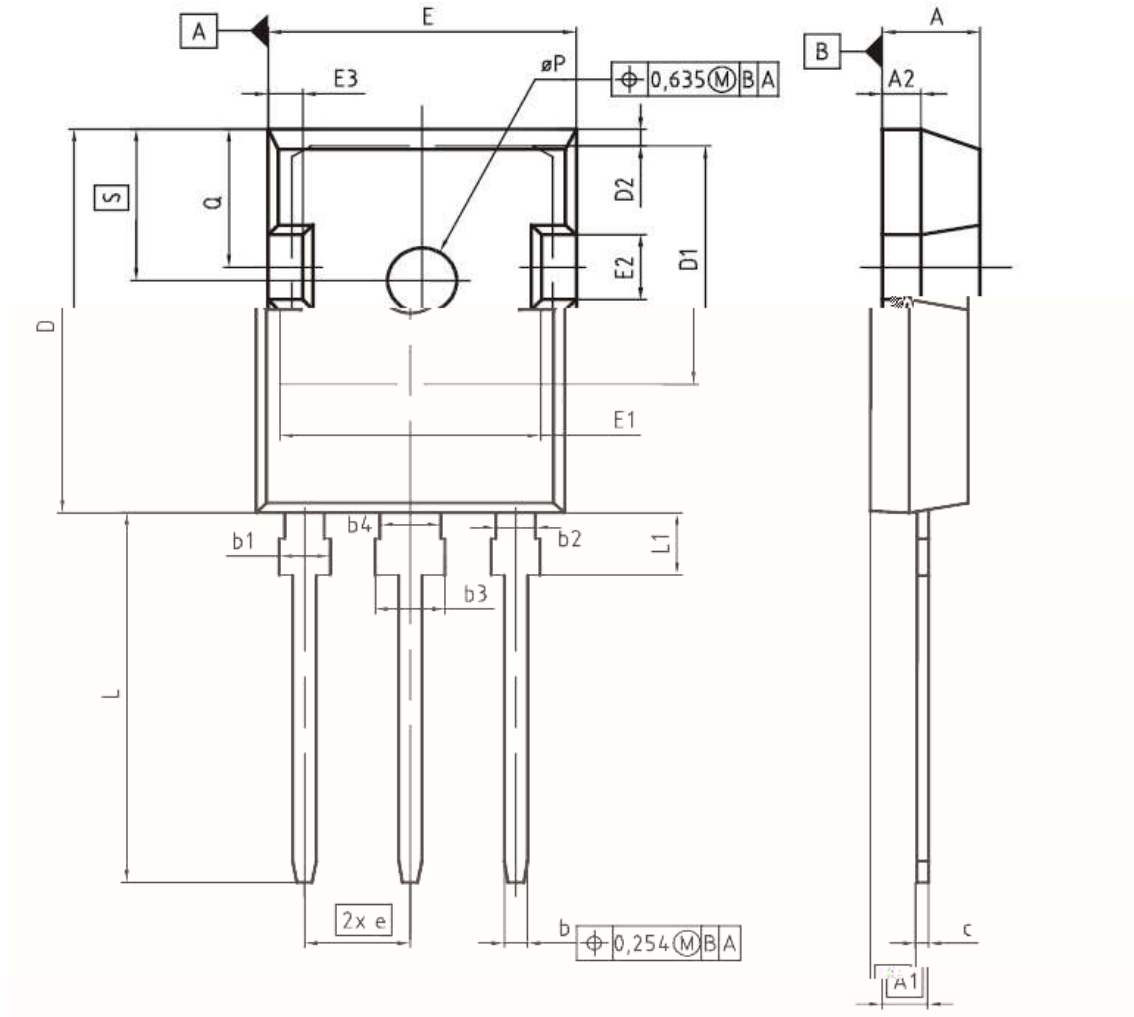

Fig. 10 Capacitance characteristics

PG-TO247-3



DIM	MILLIMETERS		INCHES	
	MIN	MAX	MIN	MAX
A	4.83	5.21	0.190	0.205
A1	2.27	2.54	0.089	0.100
A2	1.85	2.16	0.073	0.085
b	1.07	1.33	0.042	0.052
b1	1.90	2.41	0.075	0.095
b2	1.90	2.16	0.075	0.085
b3	2.87	3.38	0.113	0.133
b4	2.87	3.13	0.113	0.123
c	0.55	0.68	0.022	0.027
D	20.80	21.10	0.819	0.831
D1	16.25	17.35	0.640	0.683
D2	0.95	1.35	0.037	0.053
E	15.70	16.13	0.618	0.635
E1	13.10	14.15	0.516	0.557
E2	3.68	5.10	0.145	0.201
E3	1.00	2.60	0.039	0.102
e	5.44 (BSC)		0.214 (BSC)	
N	3		3	
L	19.80	20.32	0.780	0.800
L1	4.10	4.47	0.161	0.176
øP	3.50	3.70	0.138	0.146
Q	5.49	6.00	0.216	0.236
S	6.04	6.30	0.238	0.248