



YGW60N65T1

650V /60A Trench Field Stop IGBT

Lu-Semi 650V Trench Field Stop IGBTs offer low switching losses, high energy efficiency and high avalanche ruggedness for motion control, solar application and welding mac

i

Maximum Ratings $T_j = 25$ unless otherwise specified

Parameter	Symbol	Value	Unit
Collector-Emitter Breakdown Voltage	V_{CE}	650	V
DC collector current, limited by T_{jmax} $T_C = 25^\circ\text{C}$ $T_C = 100^\circ\text{C}$	I_C	120 60	A
Diode Forward current, limited by T_{jmax} $T_C = 25^\circ\text{C}$ $T_C = 100^\circ\text{C}$	I_F	120 60	A
Continuous Gate-emitter voltage	V_{GE}	± 20	V
Transient Gate-emitter voltage	V_{GE}	± 30	V
Turn off safe operating area $V_{CE} = 650\text{V}$, $T_j = 150^\circ\text{C}$	-	180	A
Pulse collector current, $V_{GE} = 15\text{V}$, t_p limited by T_{jmax}	I_{CM}	180	A
Power dissipation, $T_j = 25^\circ\text{C}$	P_{tot}	260	W
Operating junction temperature	T_j	-40...+150	$^\circ\text{C}$
Storage temperature	T_s	-55...+150	$^\circ\text{C}$
Soldering temperature, wave soldering 1.6mm (0.063in.) from case for 10s	-	260	$^\circ\text{C}$

Thermal Resistance

Parameter	Symbol	Max. Value	Unit
IGBT thermal resistance, junction - case	$R(j-c)$	0.48	K/W
Diode thermal resistance, junction - case	$R(j-c)$	1.1	K/W
Thermal resistance, junction - ambient	$R(j-a)$	40	K/W

Electrical Characteristics $T_j = 25$ unless otherwise specified

Parameter	Symbol	Conditions	Min	Typ	Max	Unit
Static						
Collector-Emitter Breakdown Voltage	BV_{CES}	$V_{GE}=0V, I_C=250\mu A$	650		-	V
		$V_{GE}=0V, I_C=1mA$	650			V
Gate Threshold Voltage	$V_{GE(th)}$	$V_{GE}=V_{CE}, I_C=250\mu A$	4.0	5.0	6.0	V
Collector-Emitter Saturation Voltage	$V_{CE(sat)}$	$V_{GE}=15V, I_C=60A$ $T_j = 25^\circ C$ $T_j = 150^\circ C$	-	1.85	2.2	V
			-	2.25		V
Zero gate voltage collector current	I_{CES}	$V_{CE} = 650V, V_{GE} = 0V$ $T_j = 25^\circ C$ $T_j = 150^\circ C$		0.1	40 1000	μA
Gate-emitter leakage current	I_{GES}	$V_{CE} = 0V, V_{GE} = \pm 20V$			100	nA
Transconductance	gfs	$V_{CE} = 20V, I_C = 60A$	-	52	-	S

Parameter	Symbol	Conditions	Min	Typ	Max	Unit
Dynamic						
Input capacitance	C_{ies}	$V_{CE} = 30V, V_{GE} = 0V,$ $f = 1MHz$		3800		pF
Output capacitance	C_{oes}			130		
Reverse transfer capacitance	C_{res}			70		
Gate charge	Q_G	$V_{CC} = 520V, I_C = 60A,$ $V_{GE} = 15V$	-	158	-	nC

Switching Characteristic, Inductive Load

Parameter	Symbol	Conditions	Min	Typ	Max	Unit
Dynamic $T_j=25^{\circ}\text{C}$						
Turn-on Delay Time	$t_{d(on)}$	$V_{CC} = 400\text{V}, I_C = 60.0\text{A},$ $V_{GE} = 0.0/15.0\text{V},$ $R_g = 12\Omega$	-	56	-	ns
Rise Time	t_r		-	79	-	ns
Turn-off Delay Time	$t_{d(off)}$		-	165	-	ns
Fall Time	t_f		-	81	-	ns
Turn-on Energy	E_{on}		-	2.2	-	mJ
Turn-off Energy	E_{off}		-	0.89	-	mJ

Electrical Characteristics of the DIODE $T_j = 25$ unless otherwise specified

Parameter	Symbol	Conditions	Min	Typ	Max	Unit
Dynamic						
Diode Forward Voltage	V_{FM}	$I_F = 60\text{A}$	-	2.0	-	V
Reverse Recovery Time	T_{rr}	$I_F = 50\text{A},$ $V_R = 400\text{V},$ $di/dt = 100\text{A}/\mu\text{s},$	-	20	-	ns
Reverse Recovery Current	I_{rr}		-	10	-	A
Reverse Recovery Charge	Q_{rr}		-	100	-	nC

Fig. 1 FBSOA characteristics

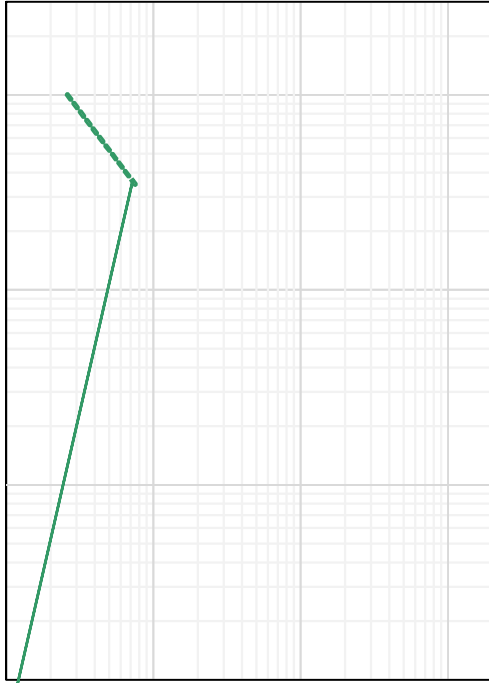

Fig. 2 Power dissipation as a function of T_c

Fig. 3 Output characteristics

Fig. 4 Saturation voltage characteristics



Fig. 5 Switching

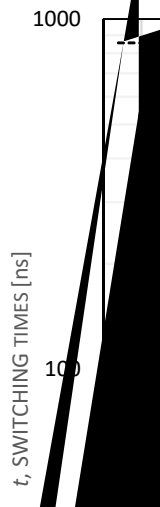

Fig. 9 Gate charge characteristics

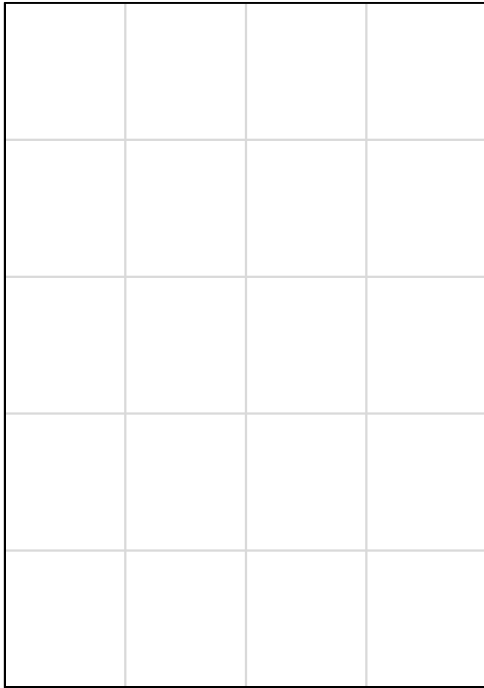
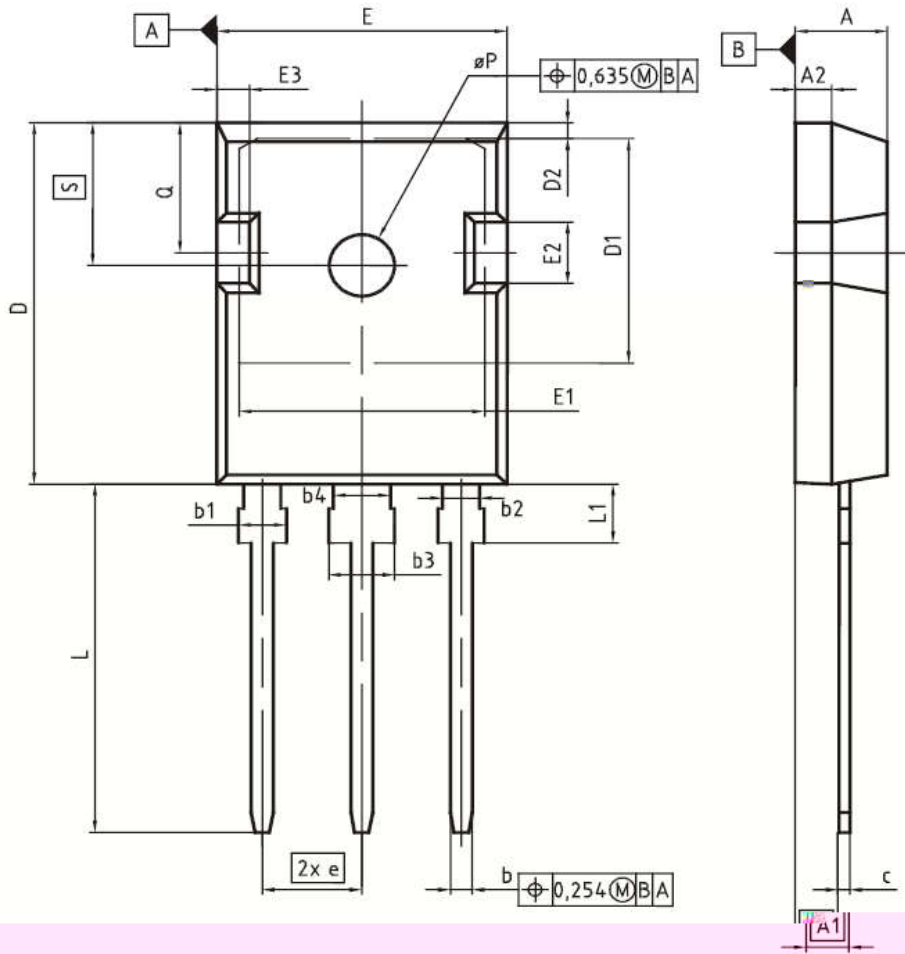

Fig. 10 Capacitance characteristics

PG-TO247-3

DIM	MILLIMETERS		INCHES	
	MIN	MAX	MIN	MAX
A	4.83	5.21	0.190	0.205
A1	2.27	2.54	0.089	0.100
A2	1.85	2.16	0.073	0.085
b	1.07	1.33	0.042	0.052
b1	1.90	2.41	0.075	0.095
b2	1.90	2.41	0.075	0.095
b3	2.87	3.38	0.113	0.133
b4	2.87	3.13	0.113	0.123
c	0.55	0.68	0.022	0.027
D	20.80	21.10	0.819	0.831
D1	16.25	17.65	0.640	0.695
D2	0.95	1.35	0.037	0.053
E	15.70	16.13	0.618	0.635
E1	13.10	14.15	0.516	0.557
E2	3.68	5.10	0.145	0.201
E3	1.00	2.60	0.039	0.102
e	5.44 (BSC)		0.214 (BSC)	
N	3		3	
L	19.80	20.32	0.780	0.800
L1	4.10	4.47	0.161	0.176
øP	3.50	3.70	0.138	0.146
Q	5.49	6.00	0.216	0.236
S	6.04	6.30	0.238	0.248