

### Electrical Characteristics

Symbol	Parameter	Test Conditions	Min	Typ	Max	Units

### Thermal Characteristics

Symbol	Parameter	Min	Typ	Max	Units

### Package Marking and Ordering Information

Device Marking	Device	Package	Reel Size	Tape Width	Quantity

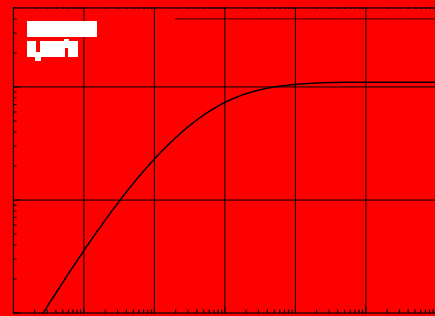
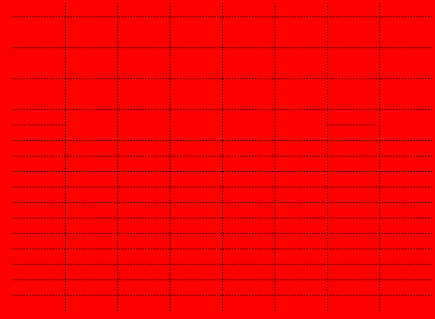

## Typical Characteristics

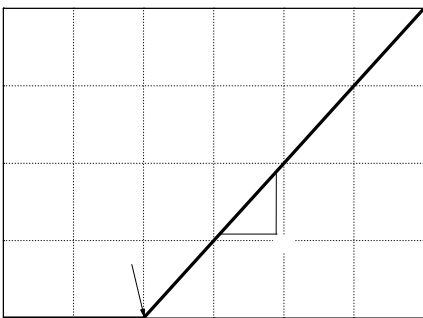
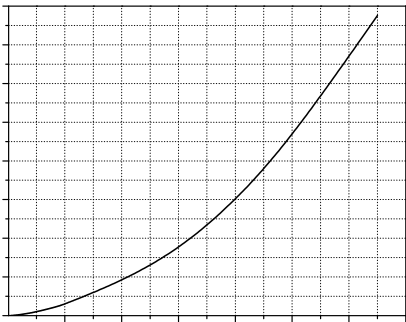
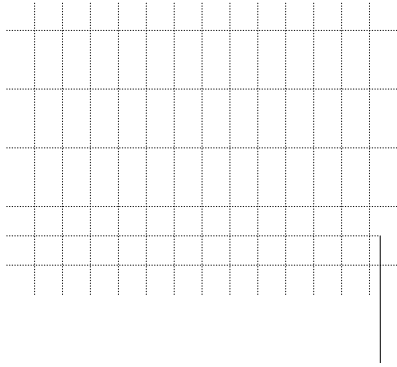

## Package Information

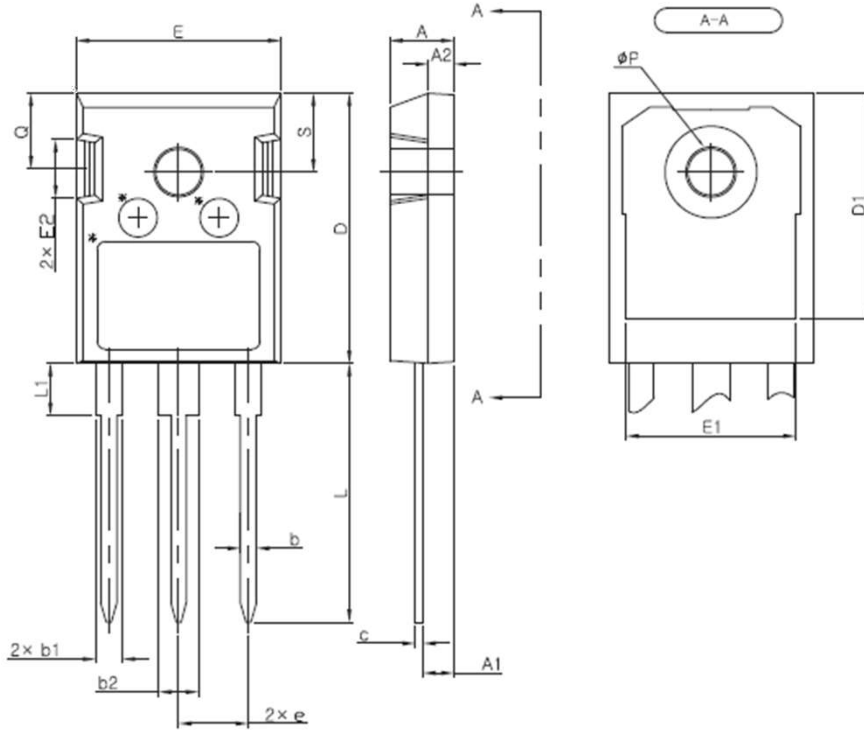

SYMBOL	MIN	NOM	MAX
A	4.80	5.00	5.20
A1	2.29	2.41	2.54
A2	1.90	2.00	2.10
b	1.10	1.20	1.30
b1	1.91	2.10	2.20
b2	2.92	3.10	3.20
c	0.50	0.60	0.70
D	20.80	21.07	21.34

# Packing Information

## Inner Box

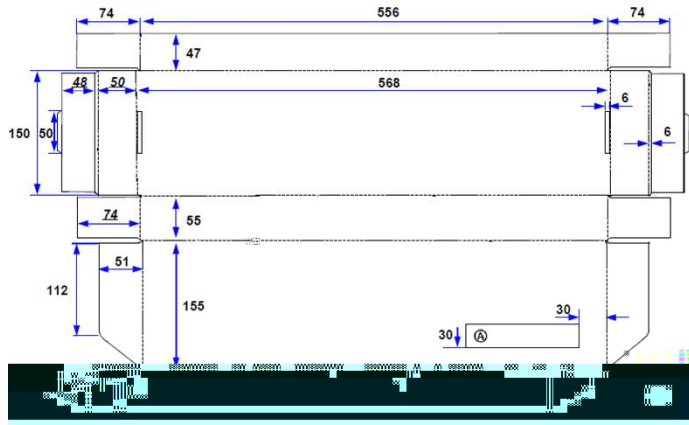

PART ID	PKG Type
PDXXXX	XX-XXXX-XX
T No.	QTY
XXXXXXXXXX	X,XXX ea
DATE : XXXX.XX.XX	

## Outer Box

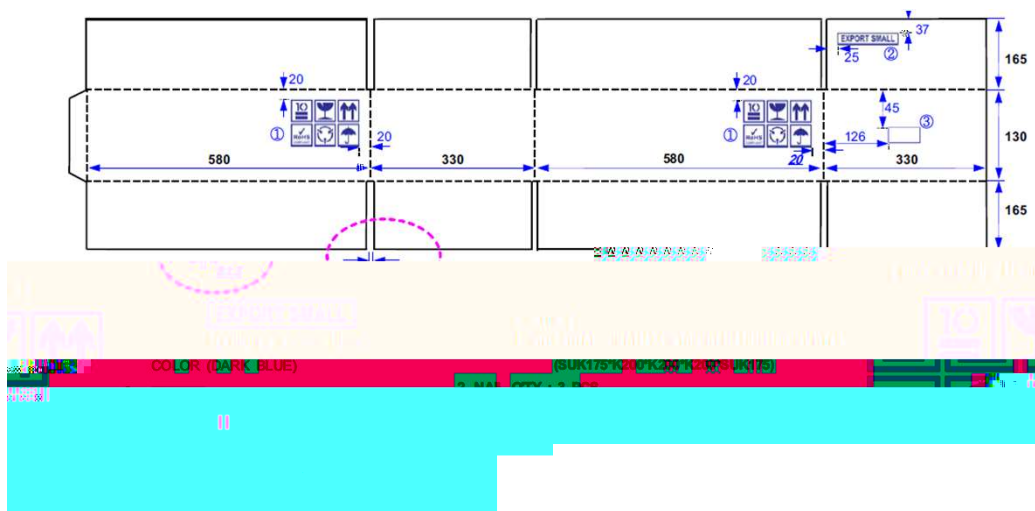

PART ID : PDXXXXXXXXEX_G	
LOT NO : XXXXXXXXXXXXX	
QTY : XX,XXXX ea	
DATE : XXXX.XX.XX	

