

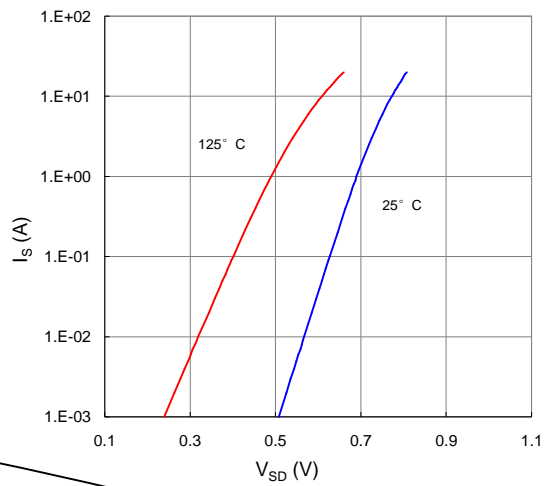

" n " " eh f

		22			
		2 "			

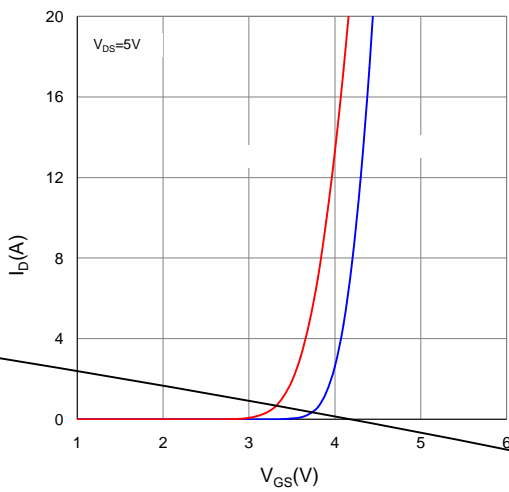

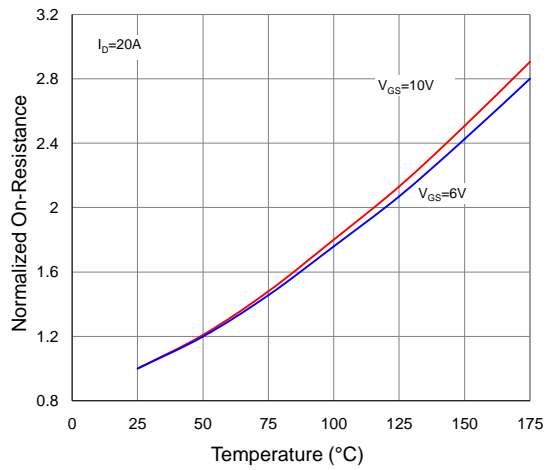
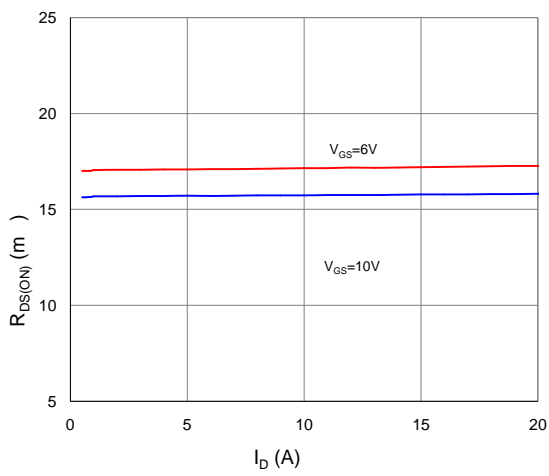
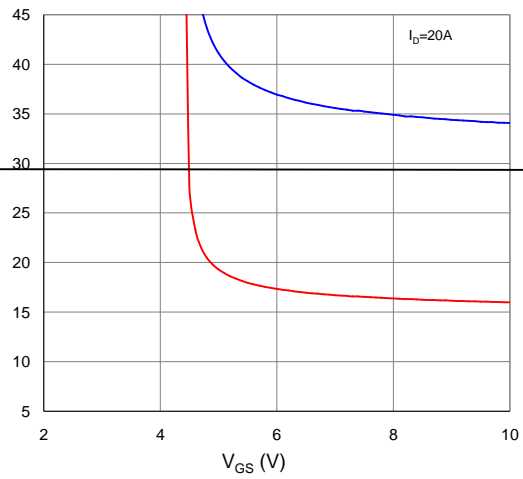
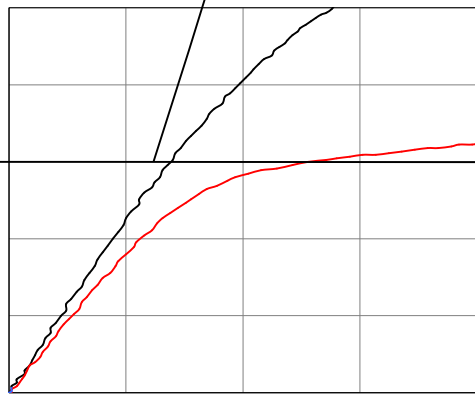
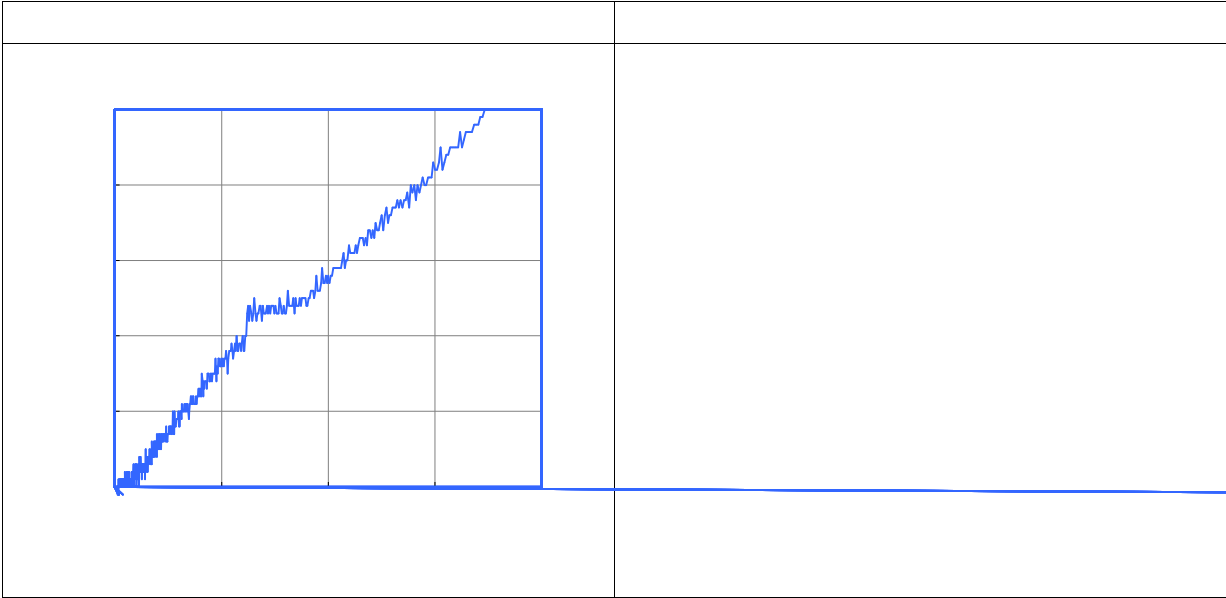

--	--

--

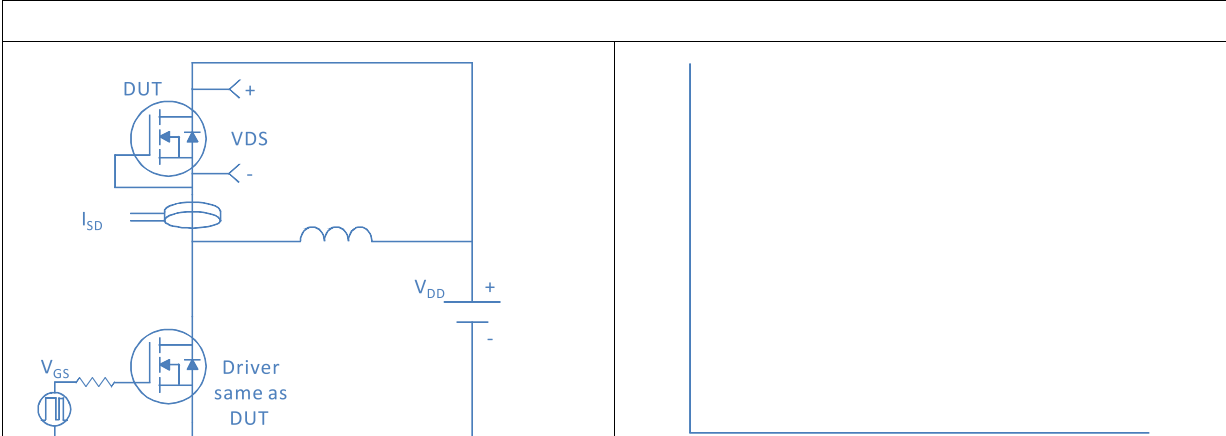
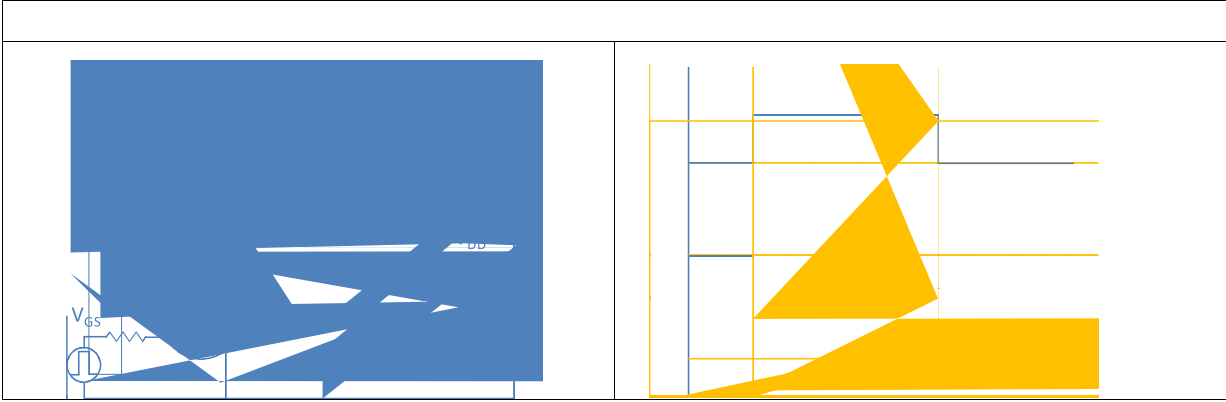
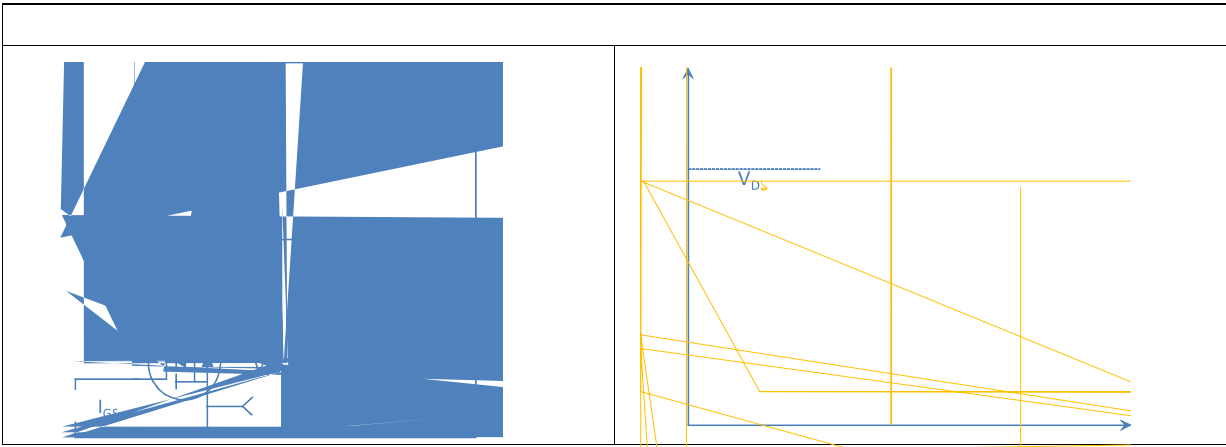
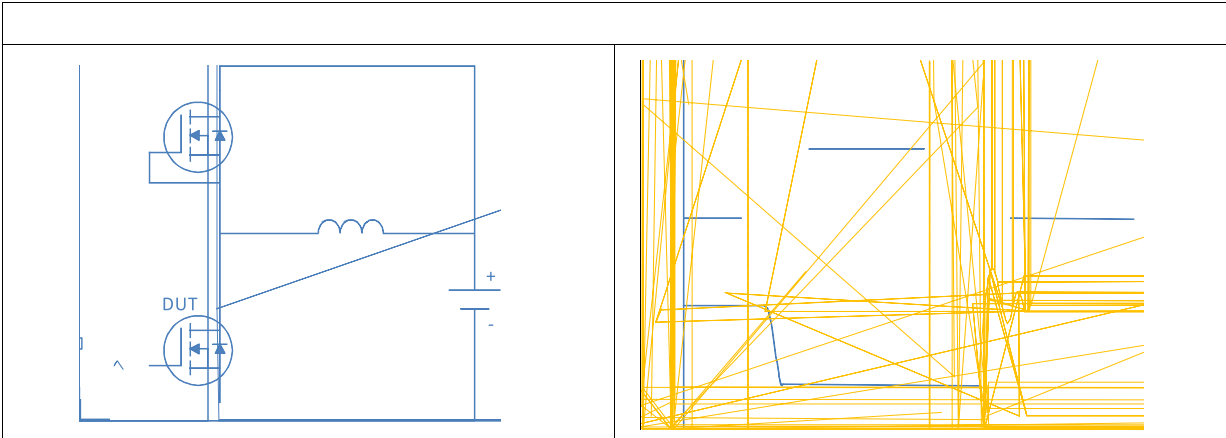

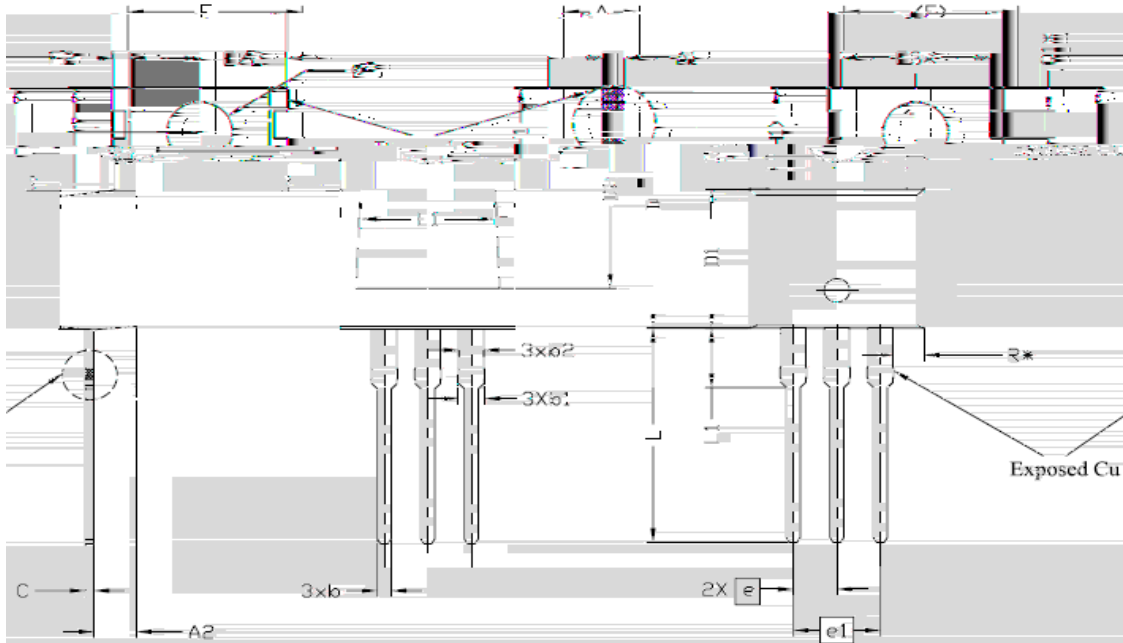

SYMBOL	DIMENSIONS			NOTES
	MIN.	NOM.	MAX.	
A	4,24	4,44	4,64	
A1	1,15	1,27	1,40	
A2	2,30	2,48	2,70	
b	0,70	0,80	0,90	
b1	1,20	1,55	1,75	
b2	1,20	1,45	1,70	
c	0,40	0,50	0,60	
D	14,70	15,37	16,00	4
D1	8,82	8,92	9,02	
D2	12,63	12,73	12,83	5
E	9,96	10,16	10,36	4,5
E1	6,86	7,77	8,89	5
E2	-	-	0,76	6
E3*	8,70REF.			
e	2,54BSC			
e1	5,08BSC			
H1	6,30	6,45	6,60	5,6
L	13,47	13,72	13,97	
L1	3,60	3,80	4,00	
∅P	3,75	3,84	3,93	
Q	2,60	2,80	3,00	
Q1*	1,73REF.			
R*	1,82REF.			

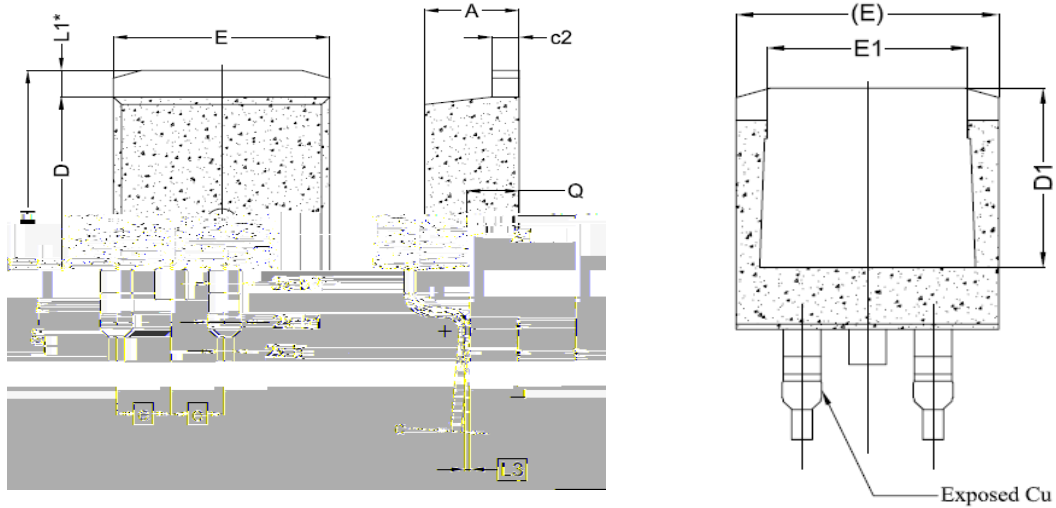

SYMBOL	DIMENSIONS		
	MIN.	NOM.	MAX.
A	4,24	4,44	4,64
A1	0,00	0,10	0,25
b	0,70	0,80	0,90
b1	1,20	1,55	1,75
b2	1,20	1,45	1,70
c	0,40	0,50	0,60
c2	1,15	1,27	1,40
D	8,82	8,92	9,02
D1	6,86	7,65	—
E	9,96	10,16	10,36
E1	6,89	7,77	7,89
e	2,54 BSC		
H	14,61	15,00	15,88
L	1,78	2,32	2,79
L1	1,36 REF.		
L2	1,50 REF.		
L3	0,25 BSC		
Q	2,30	2,48	2,70

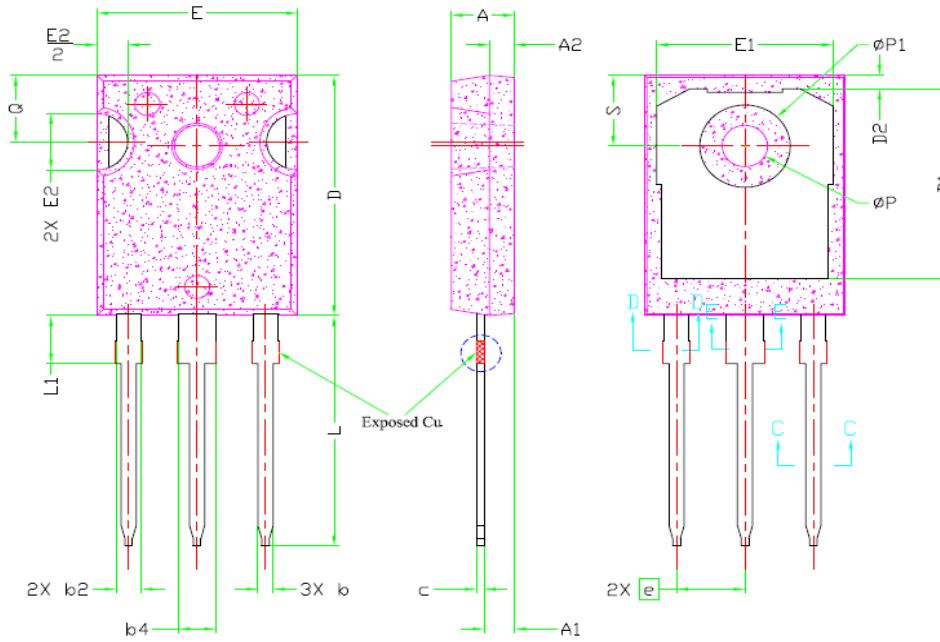

SYMBOL	DIMENSIONS			NOTES
	MIN.	NOM.	MAX.	
A	1.00	1.00	5.25	
A1	0.50	0.50	1.27	
A2	0.50	0.50	1.27	
b	0.50	0.50	1.27	
b2	0.50	0.50	1.27	
b4	0.50	0.50	1.27	
c	0.50	0.50	1.27	
D	1.00	1.00	5.25	
D1	0.50	0.50	1.27	
D2	0.50	0.50	1.27	
E	1.00	1.00	5.25	
E1	0.50	0.50	1.27	
E2	0.50	0.50	1.27	
L	0.50	0.50	1.27	
L1	0.50	0.50	1.27	
L2	0.50	0.50	1.27	
L3	0.50	0.50	1.27	
L4	0.50	0.50	1.27	
L5	0.50	0.50	1.27	
L6	0.50	0.50	1.27	
L7	0.50	0.50	1.27	
L8	0.50	0.50	1.27	
L9	0.50	0.50	1.27	
L10	0.50	0.50	1.27	
L11	0.50	0.50	1.27	
L12	0.50	0.50	1.27	
L13	0.50	0.50	1.27	
L14	0.50	0.50	1.27	
L15	0.50	0.50	1.27	
L16	0.50	0.50	1.27	
L17	0.50	0.50	1.27	
L18	0.50	0.50	1.27	
L19	0.50	0.50	1.27	
L20	0.50	0.50	1.27	
L21	0.50	0.50	1.27	
L22	0.50	0.50	1.27	
L23	0.50	0.50	1.27	
L24	0.50	0.50	1.27	
L25	0.50	0.50	1.27	
L26	0.50	0.50	1.27	
L27	0.50	0.50	1.27	
L28	0.50	0.50	1.27	
L29	0.50	0.50	1.27	
L30	0.50	0.50	1.27	
L31	0.50	0.50	1.27	
L32	0.50	0.50	1.27	
L33	0.50	0.50	1.27	
L34	0.50	0.50	1.27	
L35	0.50	0.50	1.27	
L36	0.50	0.50	1.27	
L37	0.50	0.50	1.27	
L38	0.50	0.50	1.27	
L39	0.50	0.50	1.27	
L40	0.50	0.50	1.27	
L41	0.50	0.50	1.27	
L42	0.50	0.50	1.27	
L43	0.50	0.50	1.27	
L44	0.50	0.50	1.27	
L45	0.50	0.50	1.27	
L46	0.50	0.50	1.27	
L47	0.50	0.50	1.27	
L48	0.50	0.50	1.27	
L49	0.50	0.50	1.27	
L50	0.50	0.50	1.27	
L51	0.50	0.50	1.27	
L52	0.50	0.50	1.27	
L53	0.50	0.50	1.27	
L54	0.50	0.50	1.27	
L55	0.50	0.50	1.27	
L56	0.50	0.50	1.27	
L57	0.50	0.50	1.27	
L58	0.50	0.50	1.27	
L59	0.50	0.50	1.27	
L60	0.50	0.50	1.27	
L61	0.50	0.50	1.27	
L62	0.50	0.50	1.27	
L63	0.50	0.50	1.27	
L64	0.50	0.50	1.27	
L65	0.50	0.50	1.27	
L66	0.50	0.50	1.27	
L67	0.50	0.50	1.27	
L68	0.50	0.50	1.27	
L69	0.50	0.50	1.27	
L70	0.50	0.50	1.27	
L71	0.50	0.50	1.27	
L72	0.50	0.50	1.27	
L73	0.50	0.50	1.27	
L74	0.50	0.50	1.27	
L75	0.50	0.50	1.27	
L76	0.50	0.50	1.27	
L77	0.50	0.50	1.27	
L78	0.50	0.50	1.27	
L79	0.50	0.50	1.27	
L80	0.50	0.50	1.27	
L81	0.50	0.50	1.27	
L82	0.50	0.50	1.27	
L83	0.50	0.50	1.27	
L84	0.50	0.50	1.27	
L85	0.50	0.50	1.27	
L86	0.50	0.50	1.27	
L87	0.50	0.50	1.27	
L88	0.50	0.50	1.27	
L89	0.50	0.50	1.27	
L90	0.50	0.50	1.27	
L91	0.50	0.50	1.27	
L92	0.50	0.50	1.27	
L93	0.50	0.50	1.27	
L94	0.50	0.50	1.27	
L95	0.50	0.50	1.27	
L96	0.50	0.50	1.27	
L97	0.50	0.50	1.27	
L98	0.50	0.50	1.27	
L99	0.50	0.50	1.27	
L100	0.50	0.50	1.27	